



Iran University of Science & Technology  
Electrical Engineering Faculty  
Electronics Department

# Battery Management Systems

## Slide 1: Battery Fundamentals

By: M.Razeghizadeh

(2<sup>nd</sup> semester 1404-1405 (2026))

(1<sup>st</sup> Edition)

<http://razeghizade.pudica.ir>

# Battery Fundamentals

## Preliminaries

# Terminology: Cell vs. Battery

## The Cell

- **Cell** smallest individual electrochemical unit.
- Delivers a voltage dependent strictly on cell chemistry.
- Example: A single NiMH cylinder = 1.2V.

## The Battery

- **Battery** A group of cells connected together
- Packaged in a single physical unit.
- Example:
  - 12V Lead-Acid battery = Six 2V cells in series.
  - Most High-Voltage lithium-ion Batteries include some cells wired in series
  - Most High-Capacity lithium-ion Batteries include some cells wired in parallel

## schematic symbols



Single Cell



Battery

# Terminology: Cell vs. Battery

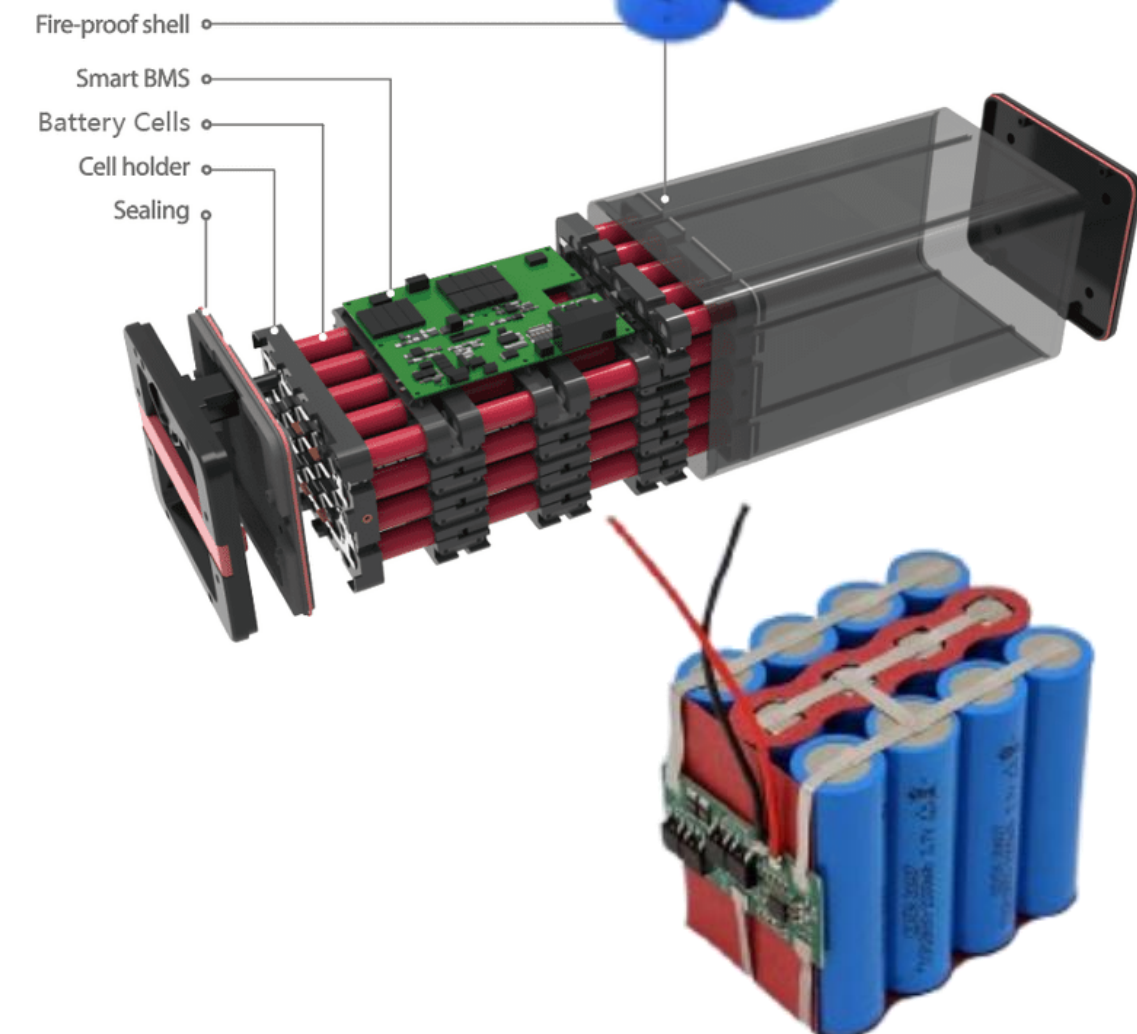
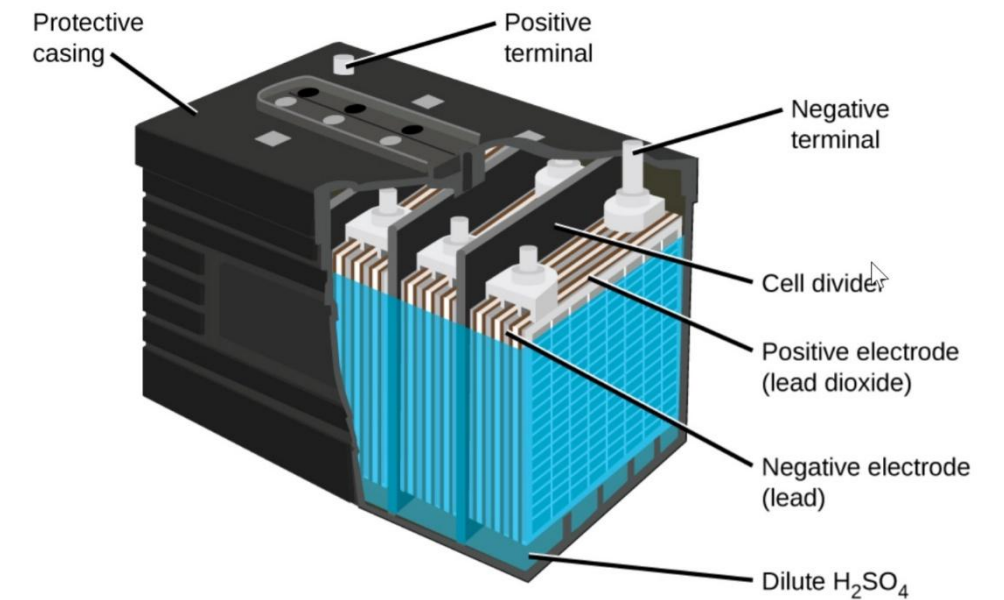

# High Voltage/Capacity Li-Battery pack

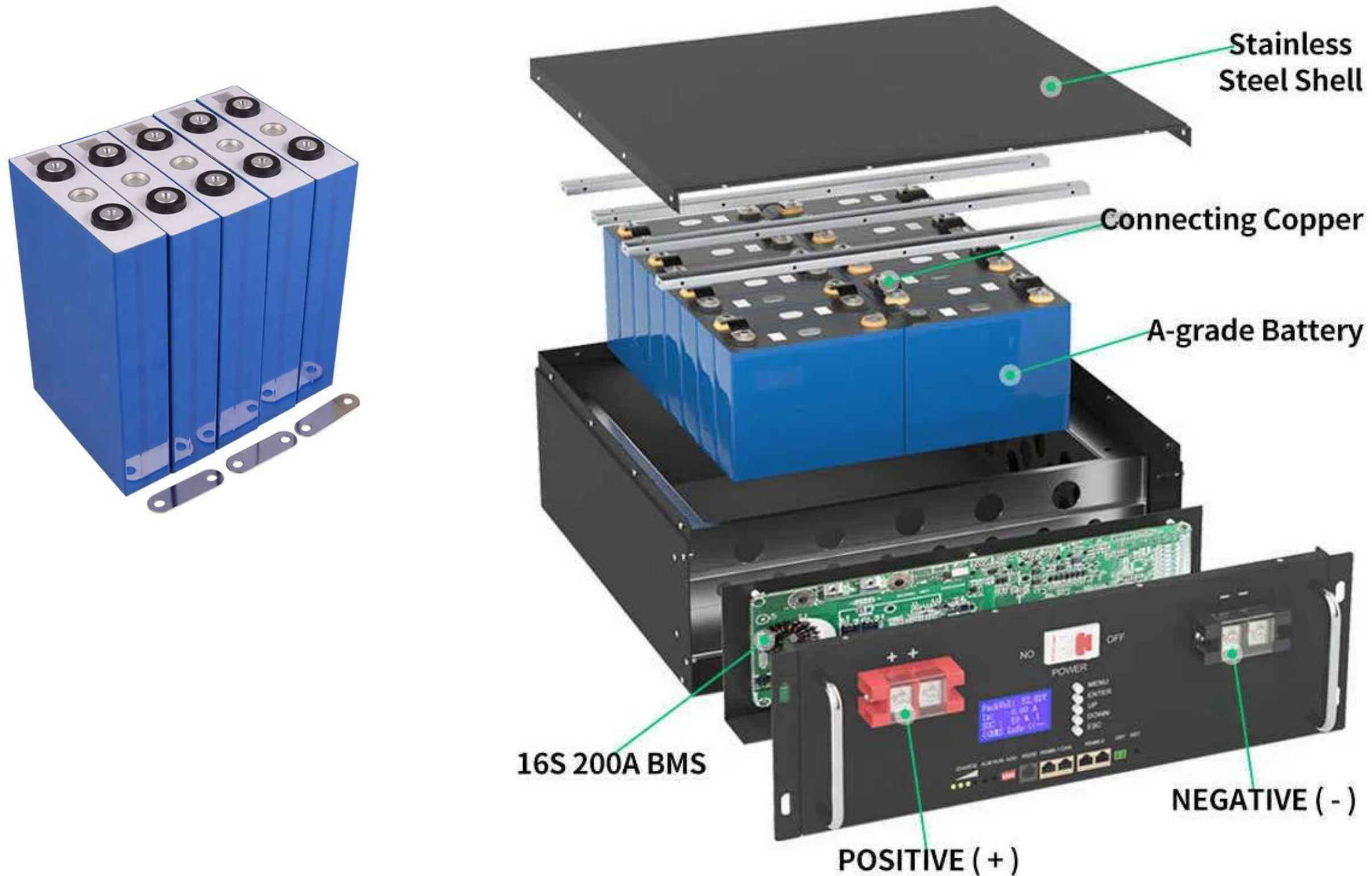

# Car Battery Pack



# Fundamental Ratings

## 1. Cell Nominal Voltage

Determined strictly by the combination of active chemicals used in the cell.

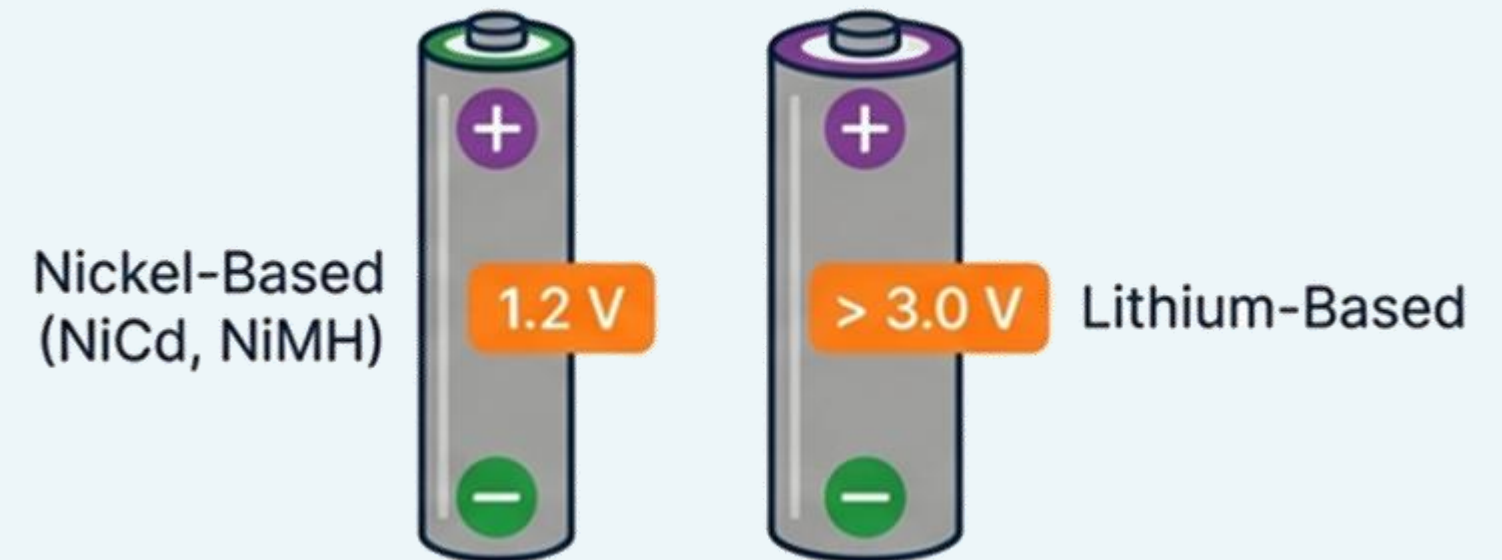

## 2. Cell Nominal Capacity

Specifies the quantity of charge the battery is rated to hold.

- Measured in Ampere-hours (Ah).

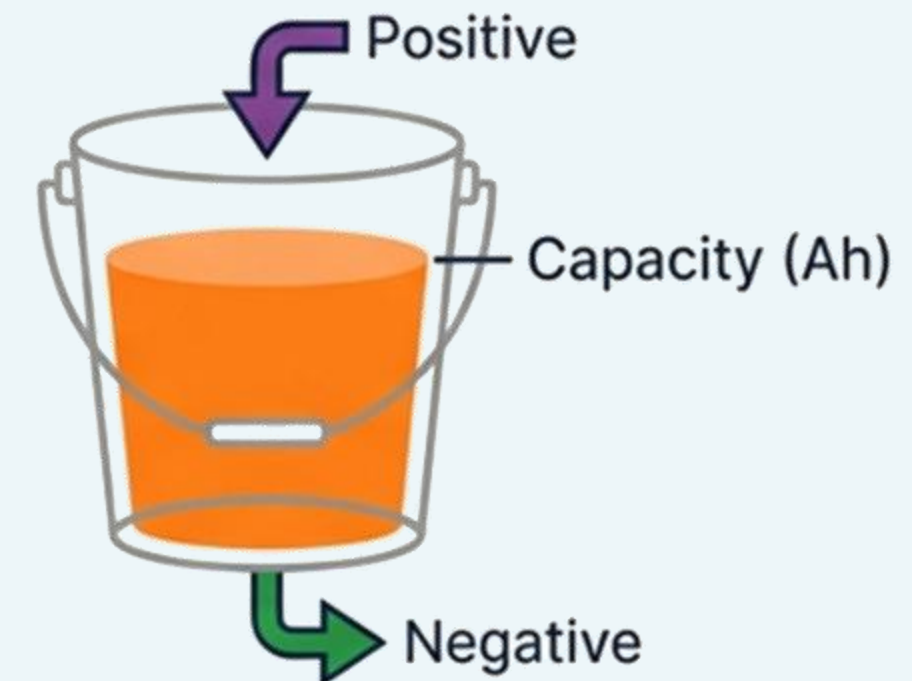

# The C-Rate: Measuring Relative Current

**Definition:** The constant-current charge or discharge rate a cell can sustain for exactly one hour.

✓ **C rate is a relative measure of cell current**

## Example: A 20 Ah Cell

### 1C Rate:

- Current: 20 A
- Duration: 1 hour

### C/10 Rate:

- Current: 2 A
- Duration: ~ 10 hours

### 10C Rate:

- Current: 200 A
- Duration: ~6 minutes

**Note:** Relationship is not strictly linear due to inefficiencies.

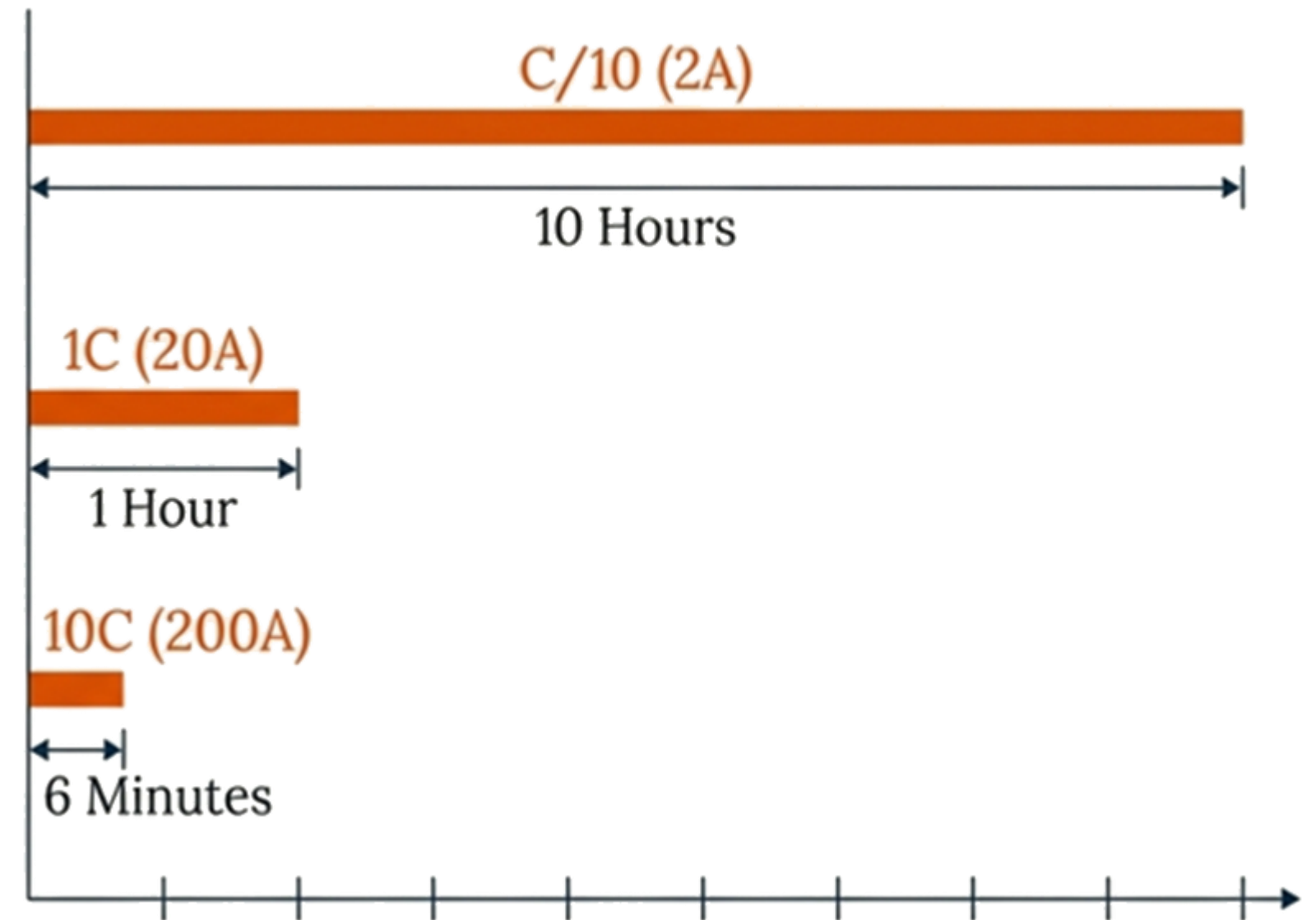

# Pack Configuration: Series vs. Parallel

## Series Connection

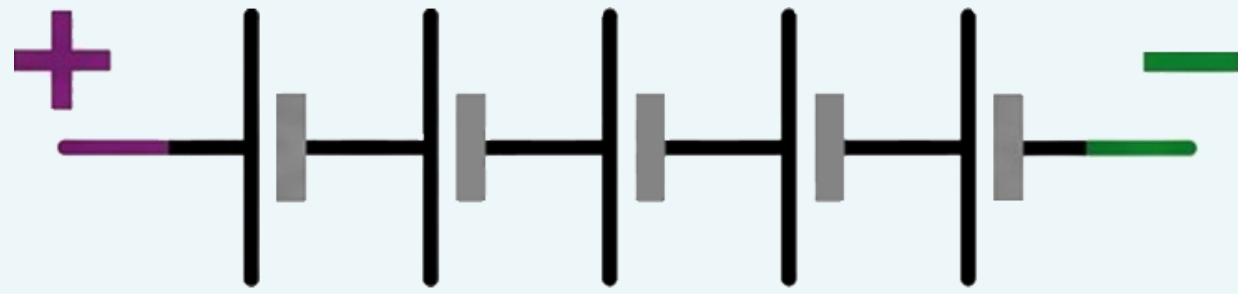

**Effect:** Adds Voltage.

**Capacity:** Remains Constant.

Example (5 cells @ 3V, 20Ah each):

- Voltage: **15 V**
- Capacity: **20 Ah**
- Energy Capacity: **300 Wh**

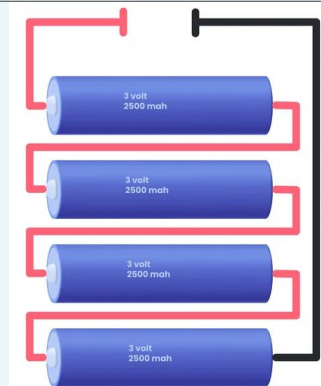

## Parallel Connection

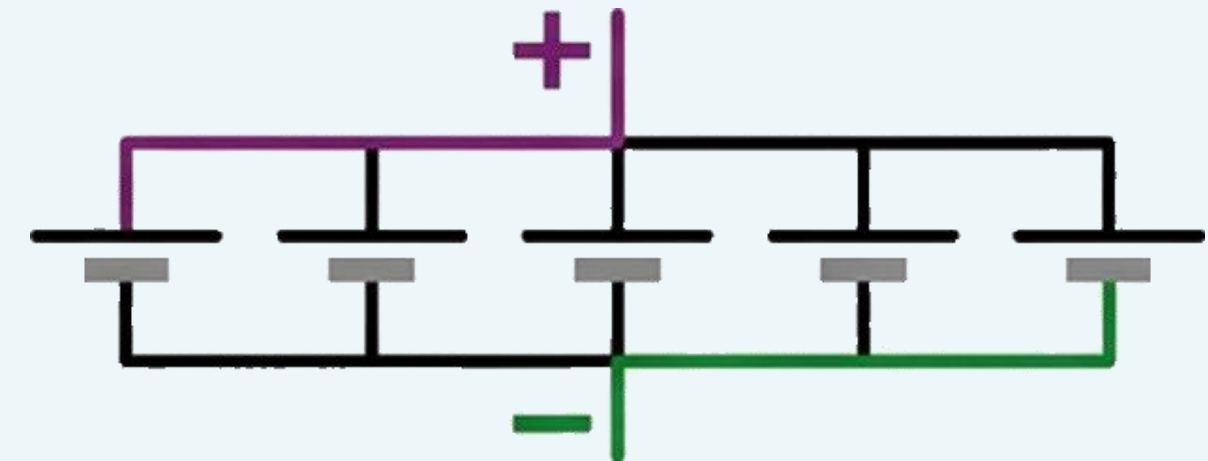

**Effect:** Adds Capacity.

**Voltage:** Remains Constant.

Example (5 cells @ 3V, 20Ah each):

- Voltage: **3V**
- Capacity: **100 Ah**
- Energy Capacity: **300 Wh**

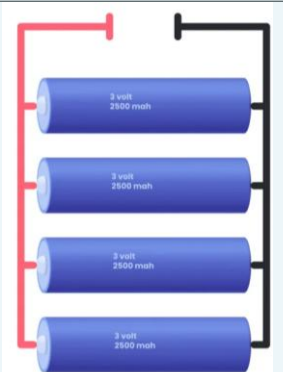

# Specific Energy vs. Energy Density

## Specific Energy (Gravimetric):

Maximum amount of stored Energy per unit weight (Wh/kg).

- Implication:

▲ Higher Specific Energy ▼ Lighter cells

- Let weight be constant:  
Material with Higher Specific Energy can store more energy

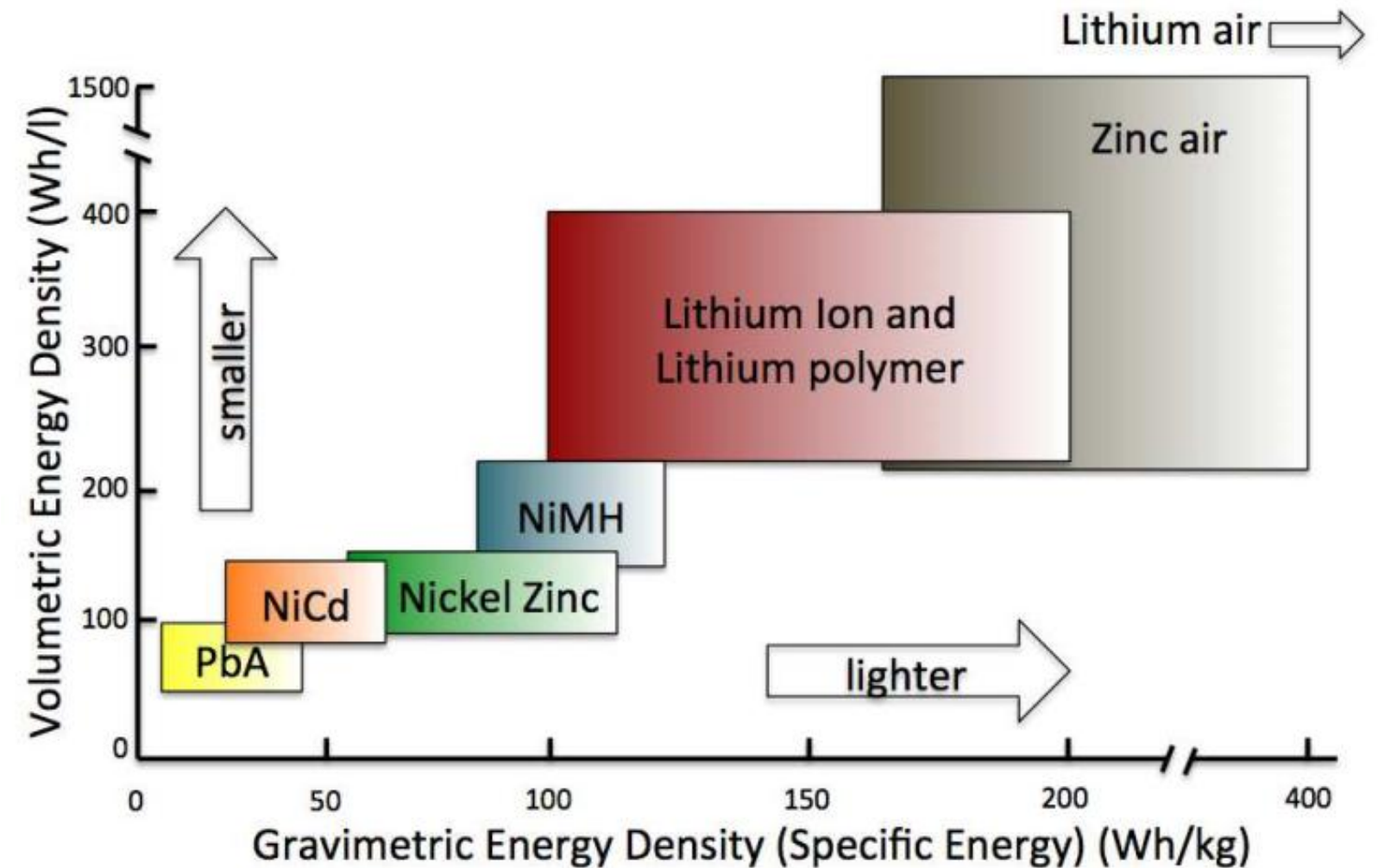

# Specific Energy vs. Energy Density

## Energy Density (Volumetric):

Maximum amount of stored Energy per unit volume (Wh/l).

- Implication:

▲ Higher Energy Density ▼ Smaller cells

- Let volume be constant:  
Material with Higher Energy Density can store more energy

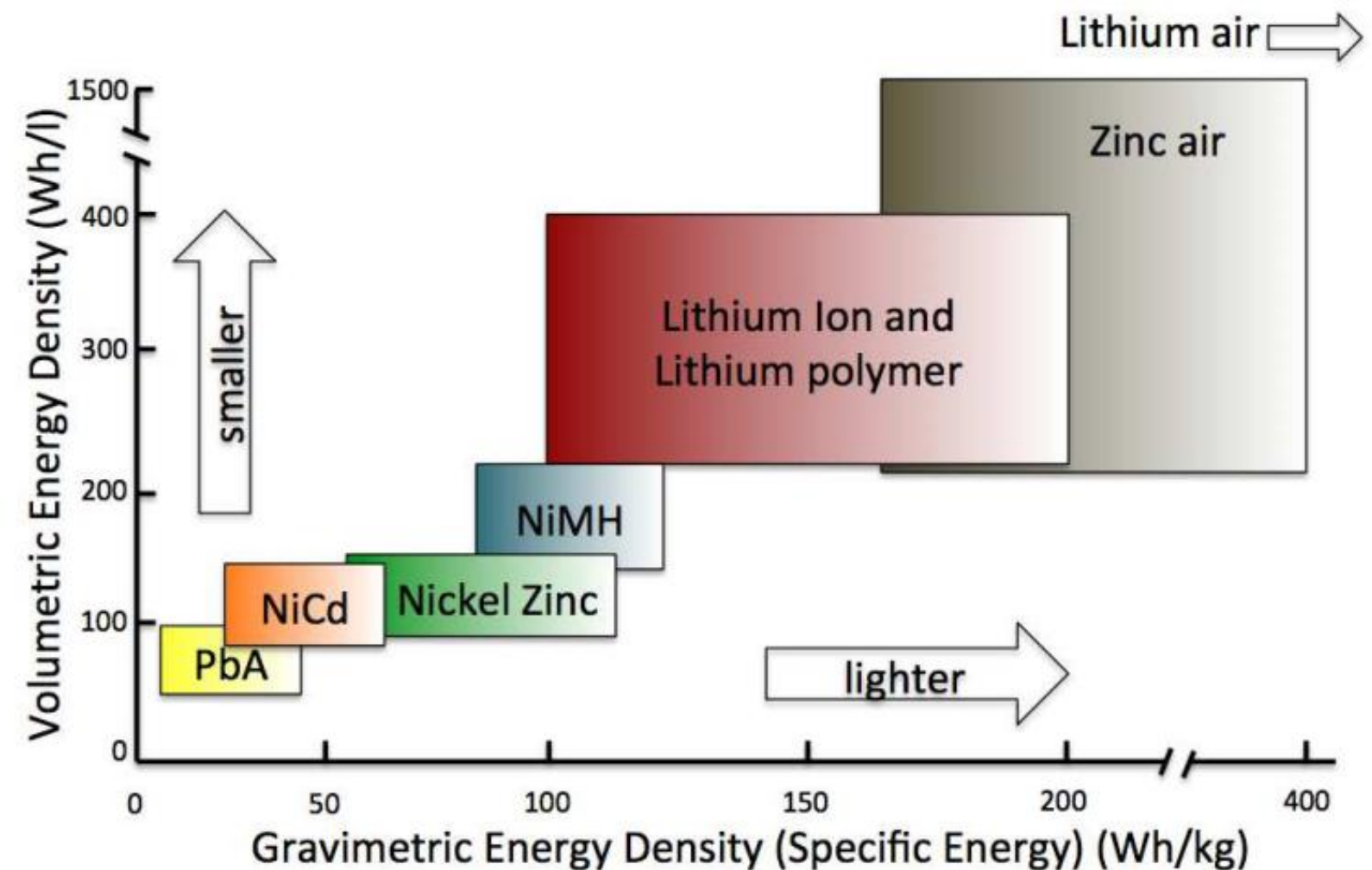

# The Balancing Act of Battery Performance: Energy, Stability and Quality

## HIGHER REACTIVITY, HIGHER ENERGY

High Energy

Increased energy density and specific energy are achieved by using more reactive chemicals.



## THE STABILITY DOWNSIDE

More reactive chemicals tend to be **unstable** and require specialized safety precautions.

## QUALITY AND MANUFACTURING VARIABLES

### IMPURITIES LIMIT PERFORMANCE

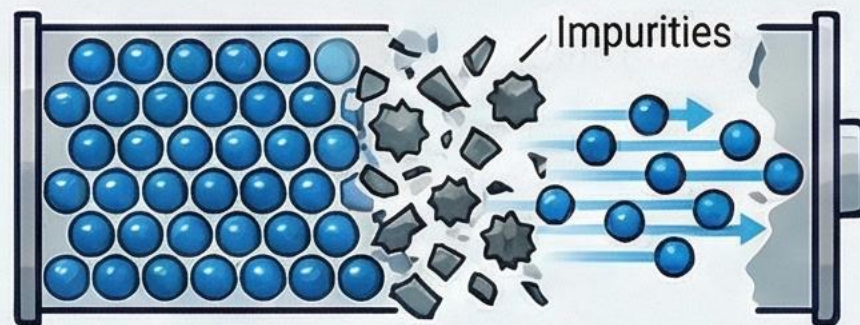

The quality of active materials is critical; even minor impurities significantly hinder cell performance.

### BRAND-TO-BRAND VARIANCE



Consistent Performance

Similar chemistries from different manufacturers can yield wildly different real-world performance results.



Variable Results

## CHEMISTRY PERFORMANCE SNAPSHOT

Chemistry Type



# Battery Fundamentals

How electrochemical cells work

# Internal Anatomy of a Cell

Each cell comprises at least three, and sometimes four components

## 1. Negative Electrode (Anode):

Metal, alloy, or hydrogen. Gives up electrons during discharge.

## 2. Positive Electrode (Cathode):

Metallic oxide or sulfide. Accepts electrons during discharge.

## 3. Electrolyte:

Ionic conductor (solvent + salt). Medium for internal ion charge transfer between the electrodes.

## 4. Separator:

Porous electronic insulator. Prevents internal shorts but allows ion flow.

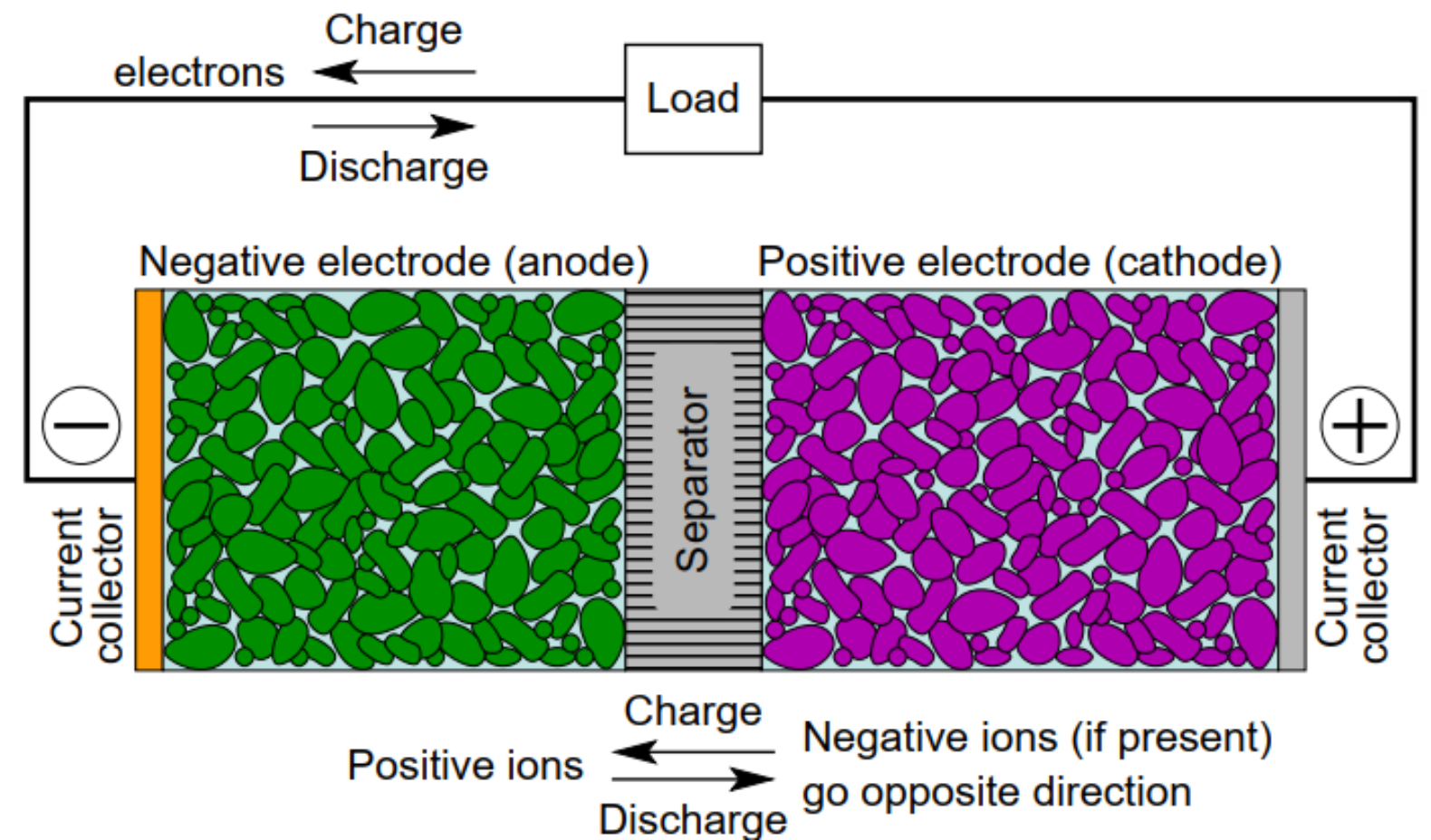

# Electrode Function & Redox Reactions

## Negative Electrode

### During Discharge:

- Acts as **Anode**.
- Is **Oxidized** (give up electrons to external circuit).

### During Charge:

- Acts as **Cathode\***.
- Is **Reduced** (accepts electrons from external circuit).

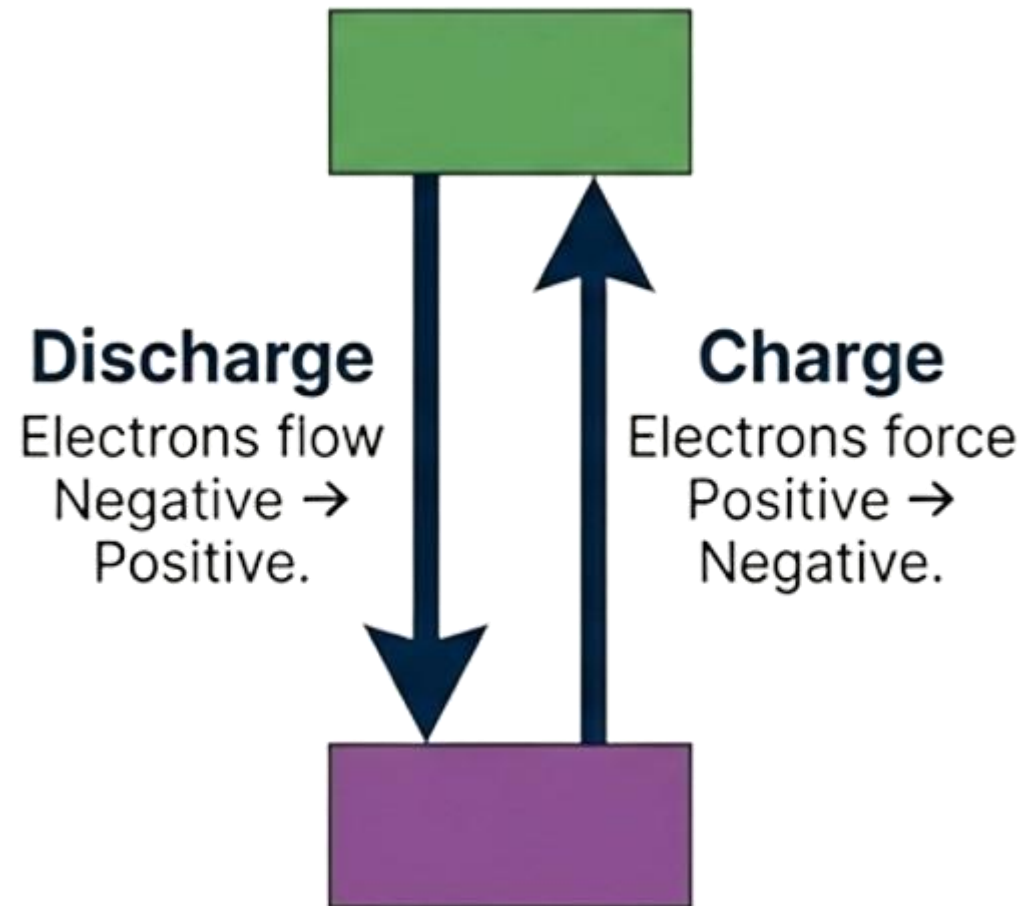

Mnemonic: **OIL RIG**  
**O**xidation **I**s **L**oss (of electrons)  
**R**eduction **I**s **G**ain (of electrons)

## Positive Electrode

### During Discharge:

- Acts as **Cathode**.
- Is **Reduced** (accepts electrons from external circuit).

### During Charge:

- Acts as **Anode\***.
- Is **Oxidized** (gives up electrons to external circuit).

\* During charging, the negative and positive electrodes are referred to as the **cathode** and **anode**, respectively. However, in practice, many people still commonly use the terms anode and cathode without considering the operating mode.

# The Electrolyte & Separator

## The Electrolyte

**Function:** Provides **ionic conductivity** between electrodes.

✓ It must be an electronic insulator to avoid self discharge.

- **Aqueous electrolytes (Water-based):** Limited to  $< 2V$ .  
(Water dissociates into H/O at higher voltages).
- **Non-Aqueous electrolytes:** Required for Lithium-based cells ( $> 2V$ ).

## The Separator

**Function:** Physically isolates electrodes to prevent internal short circuits (self discharge of the cell).

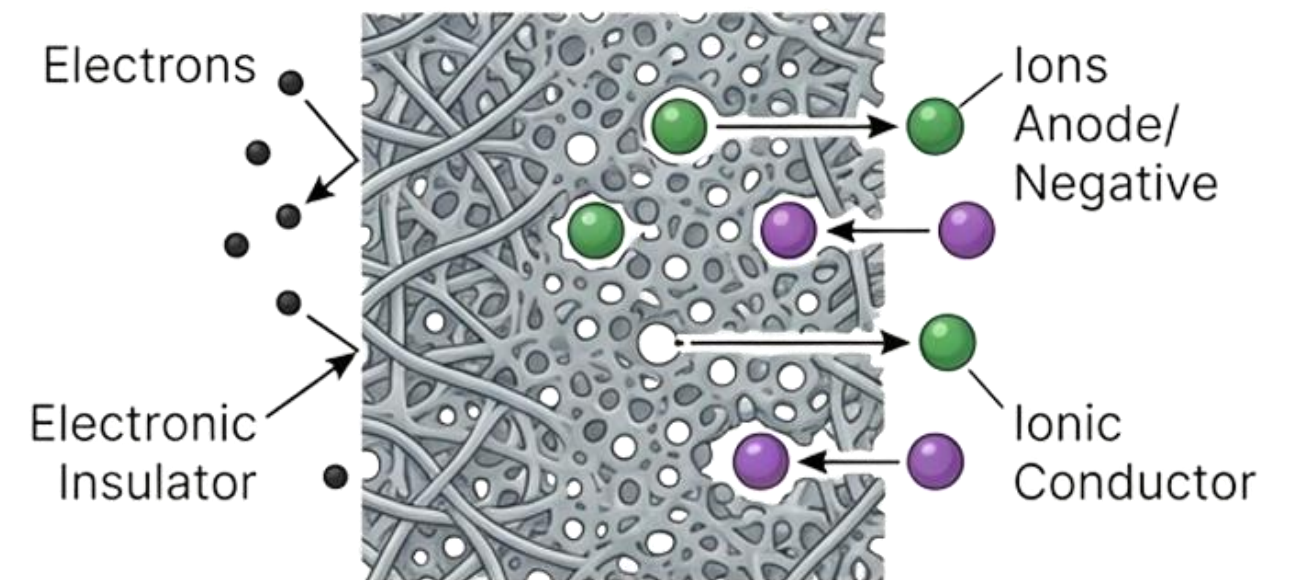

# Common electrochemical Cell Chemistries

Electrochemistry	Negative Electrode	Positive Electrode	Electrolyte	Nominal Voltage
Lead Acid	Pb	PbO <sub>2</sub>	H <sub>2</sub> SO <sub>4</sub>	2.1 V
Dry Cell	Zn	MnO <sub>2</sub>	ZnCl <sub>2</sub>	1.6 V
Alkaline	Zn	MnO <sub>2</sub>	KOH	1.5 V
Nickel Cadmium	Cd	NiOOH	KOH	1.35 V
Nickel Zinc	Zn	NiOOH	KOH	1.73 V
Zinc Air	Zn	O <sub>2</sub>	KOH	1.65 V

# The Discharge Process

## Mechanism:

- **Chemical potential** at the **Negative Electrode** favors a chemical process that would release:
  - ✓ electrons into external circuit,
  - ✓ positively charged ions into the electrolyte.
- **Chemical potential** at the **Positive Electrode** favors a chemical process that would accept:
  - ✓ electrons from the external circuit
  - ✓ positively charged ions from the electrolyte.

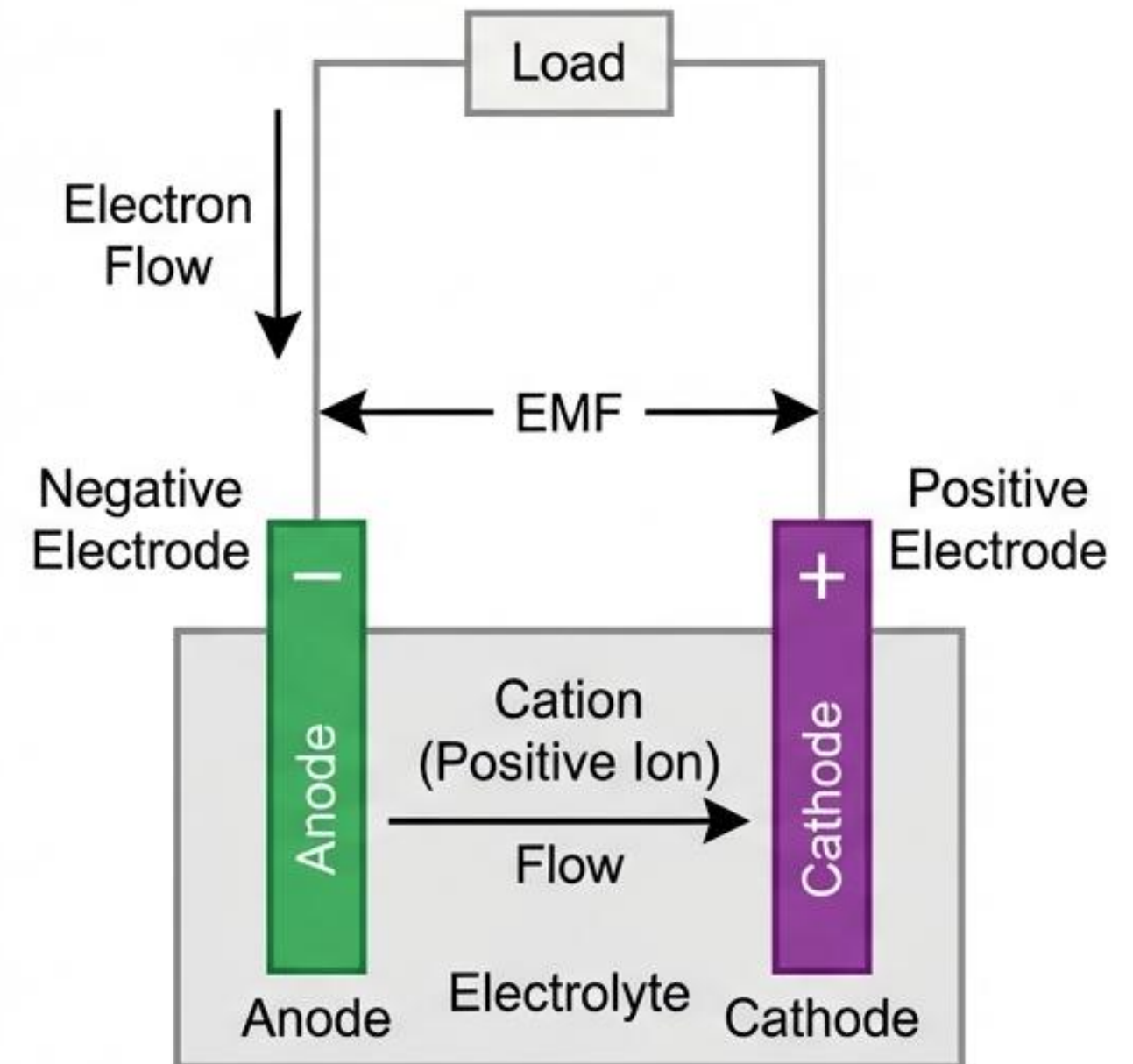

# The Discharge Process

## Mechanism:

- **EMF** (Electromotive Force) or **cell voltage**:  
The resulting "electrical pressure" or "potential difference" between the terminals.
- Cell performs work when an external circuit is completed, converting stored chemical potential energy into electrical energy on demand.

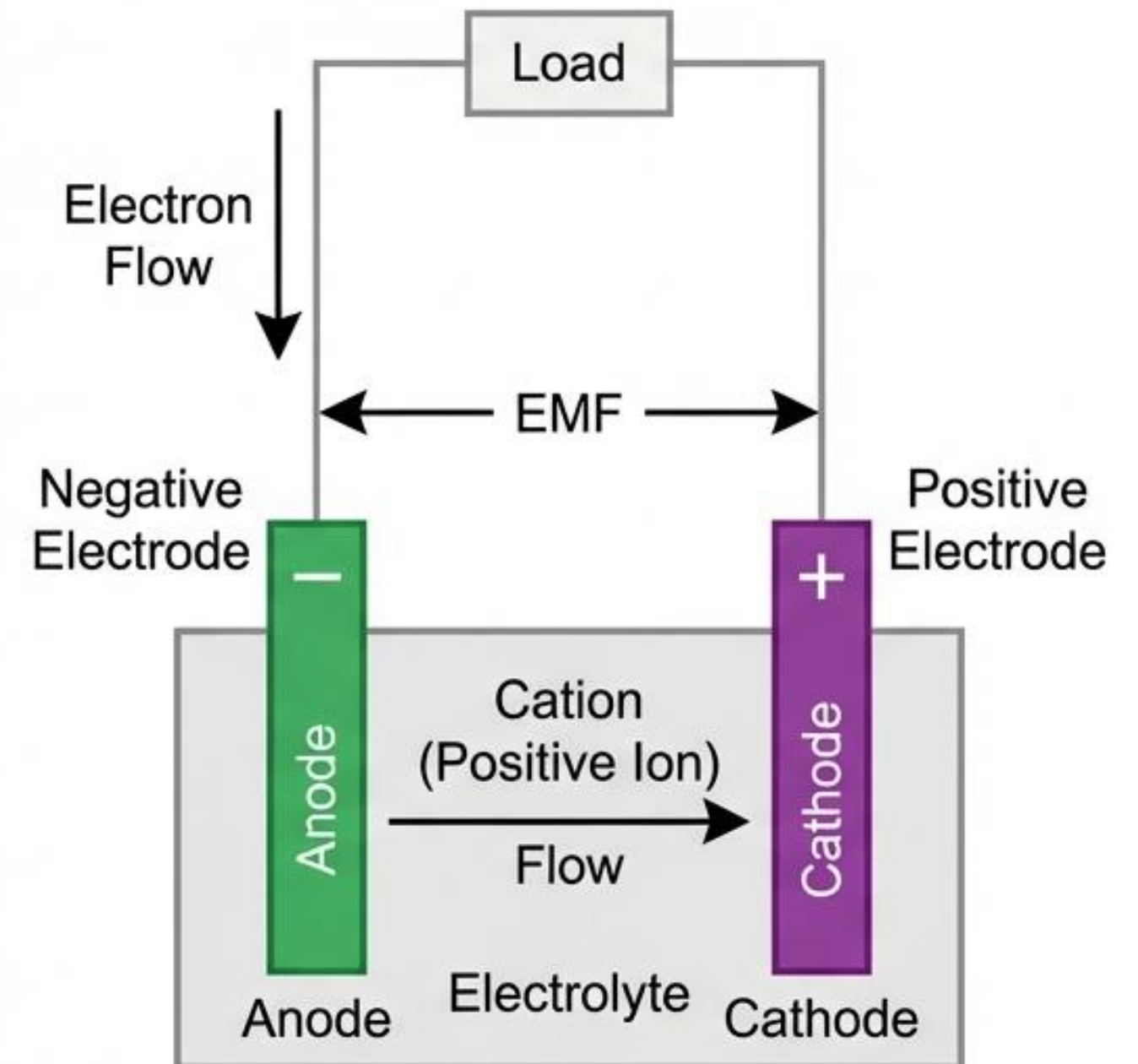

# The Charge Process: Primary vs. Secondary

## Primary Cells (Single Use)



- Reaction is **irreversible**.
- Chemical compounds are **permanently changed** and **electrical energy** is released .
- When the original compounds exhausted , the cell is **dead**.

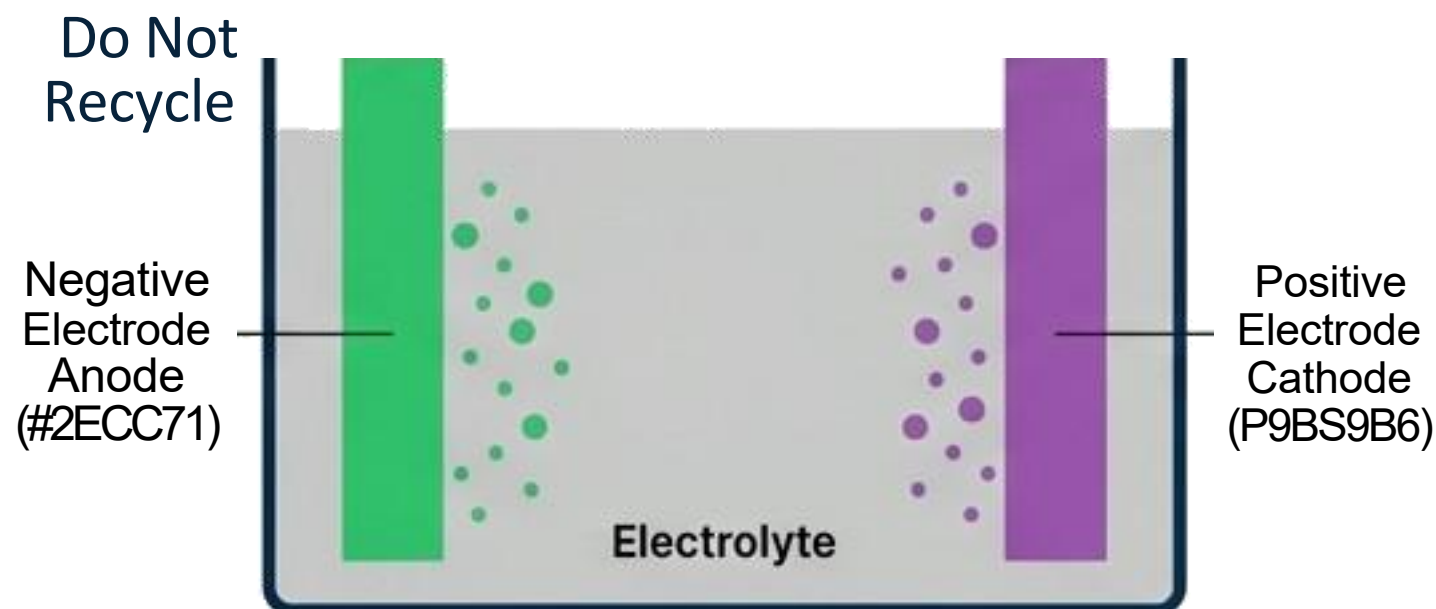

Primary cells can be used only once.

## Secondary Cells (Rechargeable)



Recharge

- Reaction is **reversible**.
- External potential “**pumps**” **energy** back in.
- In charge process:
  - Cations move **Positive -> Negative**.
  - Electrons forced **Positive -> Negative**.
- Result: Active chemicals **reconstituted** to original state.

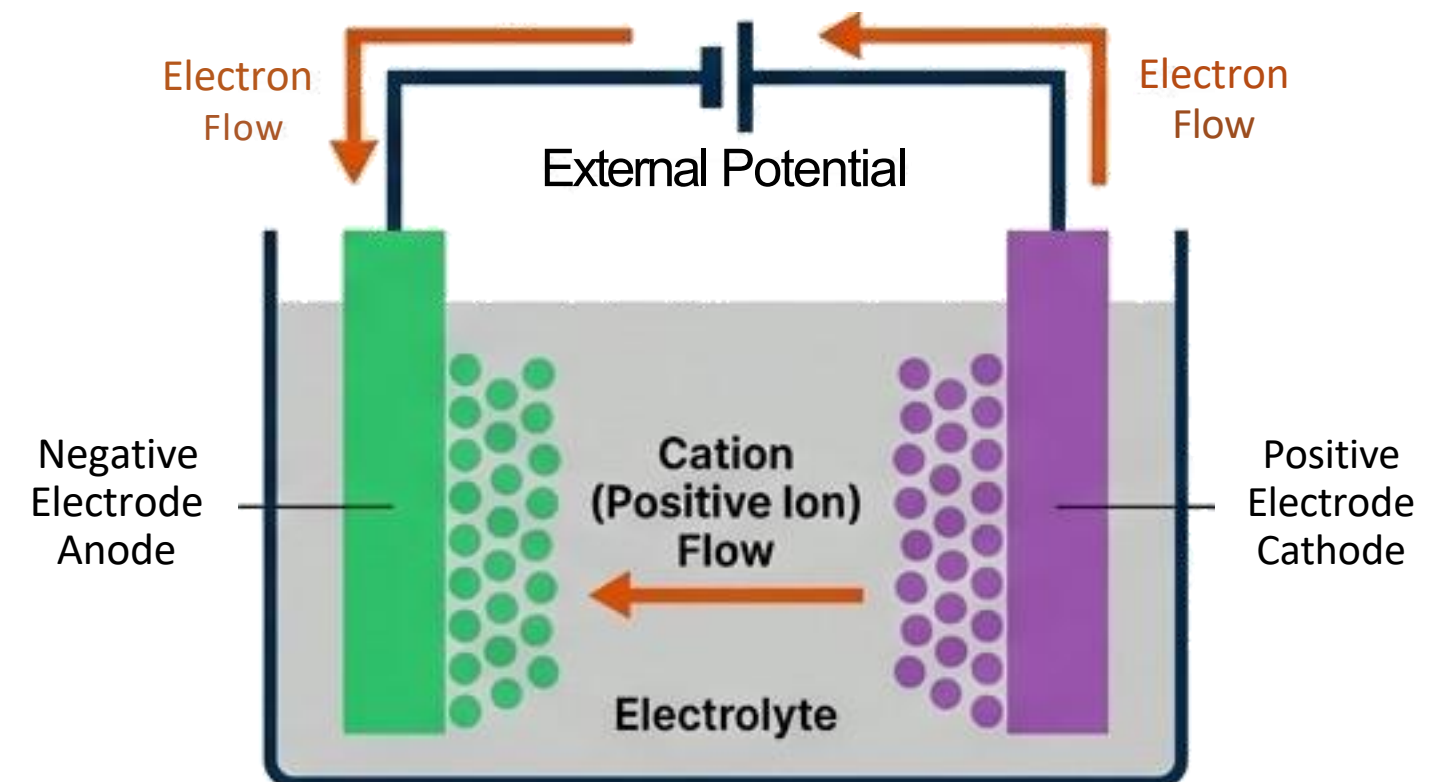

can be discharged and recharged many times

# Battery Fundamentals

## Choice of active chemicals

# Material Selection Drive Cell Performance



Electrode Materials

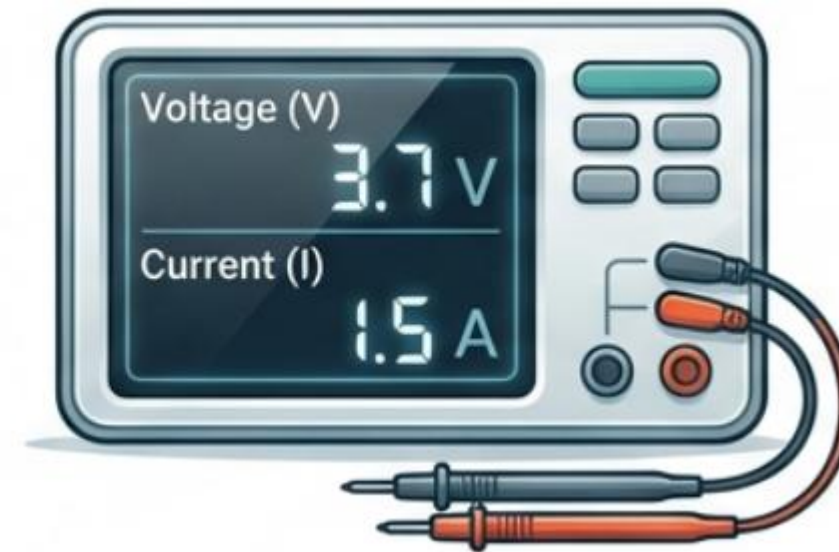

The **voltage** and **current** generated by a cell is directly related to the **types of materials** used in the **electrodes** and **electrolyte**.

# Electrode Potential

Definition: The **propensity** of a material to **gain or lose electrons** relative to another material.

The Rule:

- Compounds with **negative electrode potential** are used for **negative electrodes**
- Compounds with **positive electrode potential** for **positive electrodes**.

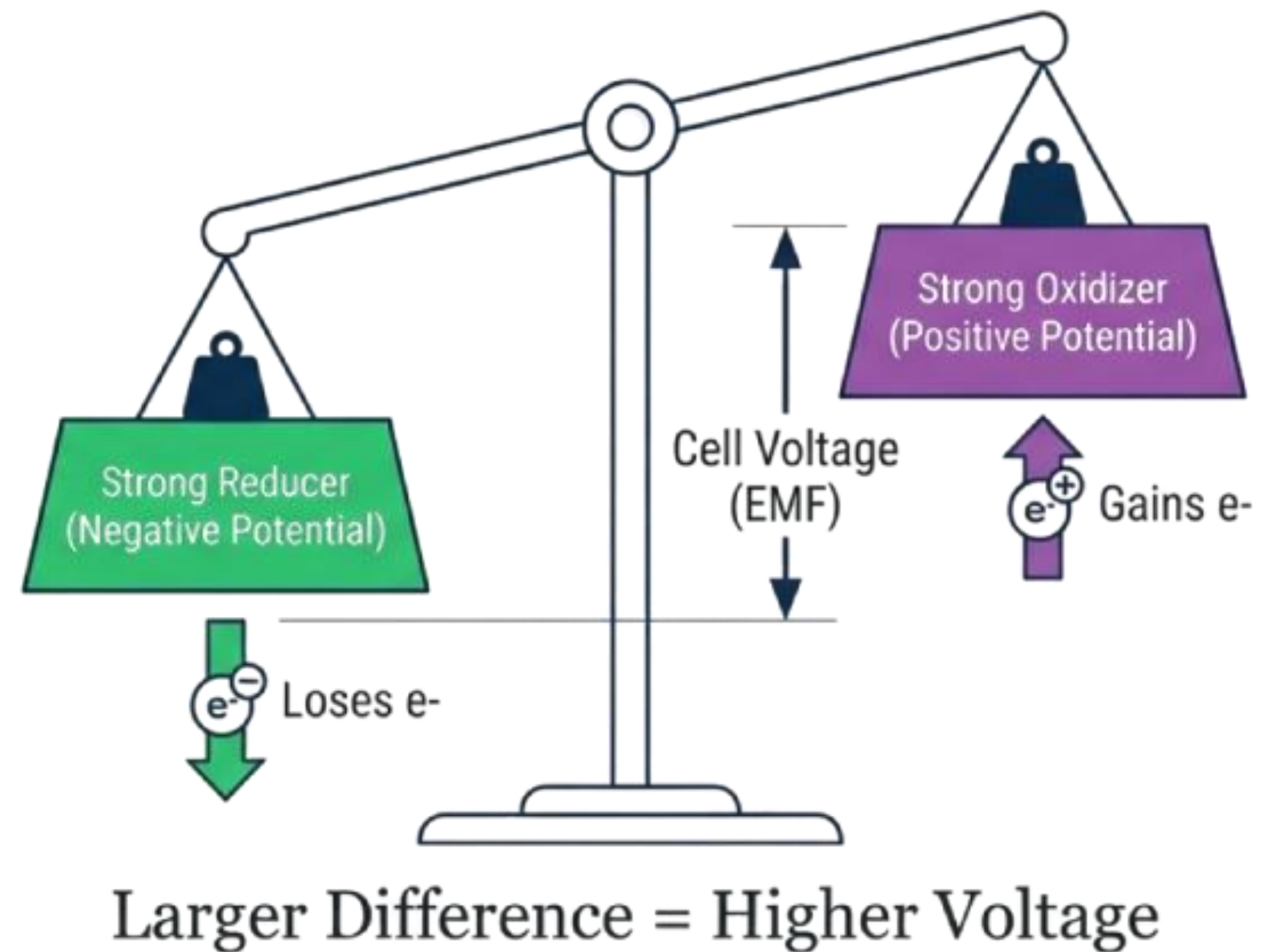

# Atomic Structure & Chemical Selection

Why do we choose specific elements as active materials?

The periodic table is color-coded to show trends in reactivity. Elements on the left are grouped as 'Strong Reducing Elements' (orange), and elements on the right are grouped as 'Strong Oxidizing Elements' (teal). The atomic number (number of protons) is indicated for each element.

1 H Hydrogen 1.00794	Strong Reducing Elements																Strong Oxidizing Elements										2 He Helium 4.002922
3 Li Lithium 6.941	4 Be Beryllium 9.01152	Atomic Number (Protons)																5 B Boron 10.811	6 C Carbon 12.0107	7 N Nitrogen 14.0067	8 O Oxygen 15.9994	9 F Fluorine 18.99842	10 Ne Neon 20.1797				
11 Na Sodium 22.98976928	12 Mg Magnesium 24.304	13 Al Aluminium 26.9815385	14 Si Silicon 28.0855	15 P Phosphorus 30.973762	16 S Sulfur 32.065	17 Cl Chlorine 35.453	18 Ar Argon 39.948																				
19 K Potassium 39.0983	20 Ca Calcium 40.078	21 Sc Scandium 44.955912	22 Ti Titanium 47.88	23 V Vanadium 50.9415	24 Cr Chromium 51.9961	25 Mn Manganese 54.938045	26 Fe Iron 55.845	27 Co Cobalt 58.9332	29 Ni Nickel 58.6934	30 Zn Zinc 65.38	31 Ga Gallium 69.723	32 Ge Germanium 72.64	33 As Arsenic 74.9216	34 Se Selenium 78.96	35 Br Bromine 79.904	36 Kr Krypton 83.9048											
37 Rb Rubidium 85.4678	38 Sr Strontium 87.62	39 Y Yttrium 88.90585	40 Zr Zirconium 91.224	41 Nb Niobium 92.90638	42 Mo Molybdenum 95.94	43 Tc Technetium (98)	44 Ru Ruthenium 101.07	46 Pd Palladium 106.42	47 Ag Silver 107.8682	48 Cd Cadmium 112.411	49 In Indium 114.818	50 Sn Tin 118.710	51 Sb Antimony 121.757	52 Te Tellurium 127.6	53 I Iodine 126.90447	54 Xe Xenon 131.29											
55 Cs Cesium 132.90545	56 Ba Barium 137.327	57-71 Lanthanides	72 Hf Hafnium 178.49	73 Ta Tantalum 180.94788	74 W Tungsten 183.84	75 Re Rhenium 186.207	76 Os Osmium 190.23	77 Ir Iridium 192.222	79 Au Gold 196.966569	80 Hg Mercury 200.59	81 Tl Thallium 204.3833	82 Pb Lead 207.2	83 Bi Bismuth 208.9804	84 Po Polonium (209)	85 At Astatine (210)	86 Rn Radon (222)											
87 Fr Francium (223)	88 Ra Radium (226)	89-103 Actinides	104 Rf Rutherfordium (261)	105 Db Dubnium (268)	106 Sg Seaborgium (266)	107 Bh Bohrium (277)	108 Hs Hassium (277)	110 Mt Meitnerium (276)	111 Rg Roentgenium (281)	112 Cn Copernicium (285)	113 Nh Nihonium (285)	114 Fl Flerovium (289)	115 Mc Moscovium (288)	116 Lv Livermorium (293)	117 Ts Tennessium (294)	118 Og Oganesson (294)											
57 La Lanthanum 138.9047	59 Pr Praseodymium 140.90766	90 Nd Neodymium 144.242	61 Pm Promethium (145)	62 Sm Samarium 150.36	63 Eu Europium 151.964	64 Gd Gadolinium 157.25	65 Tb Terbium 158.92535	66 Dy Dysprosium 162.5003	67 Ho Holmium 164.93033	68 Er Erbium 167.259	69 Tm Thulium 168.9304	70 Yb Ytterbium 173.054	71 Lu Lutetium 174.967														
80 Ac Actinium (227)	91 Pa Protactinium 231.03688	92 U Uranium 238.02891	93 Np Neptunium (237)	94 Pu Plutonium (244)	95 Am Americium (243)	96 Cm Curium (247)	97 Bk Berkelium (247)	98 Cf Californium (251)	99 Es Einsteinium (252)	100 Fm Fermium (257)	101 Md Mendelevium (258)	102 No Nubium (262)															

Reducing Elements: Grouped to the left (surplus electrons).

Oxidizing Elements: Grouped to the right (deficit of electrons).

**Key Concept:** The number of **valence electrons** determines **reactivity**. Elements on the extremes (Left and Right) are the most reactive and create the highest potentials.

# Decoding the Table: Groups and Periods

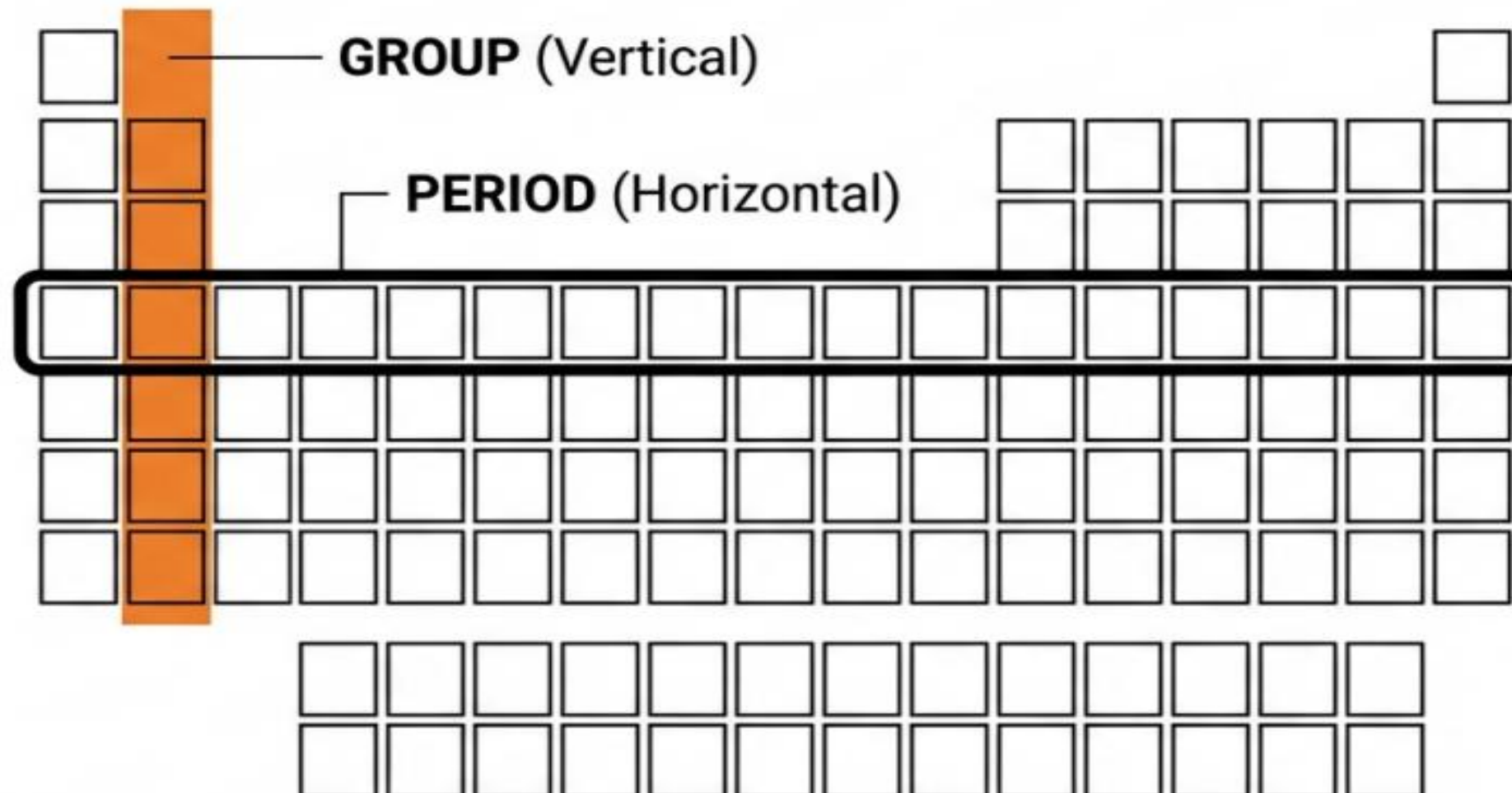

**Groups (Vertical Columns):**  
Elements within a group generally have the same number of valence electrons. They share similar chemical properties.

**Periods (Horizontal Rows):**  
Elements in a period have the same number of electron shells (orbits). This corresponds to energy levels.

# Valence Electrons: The engine of Reactivity

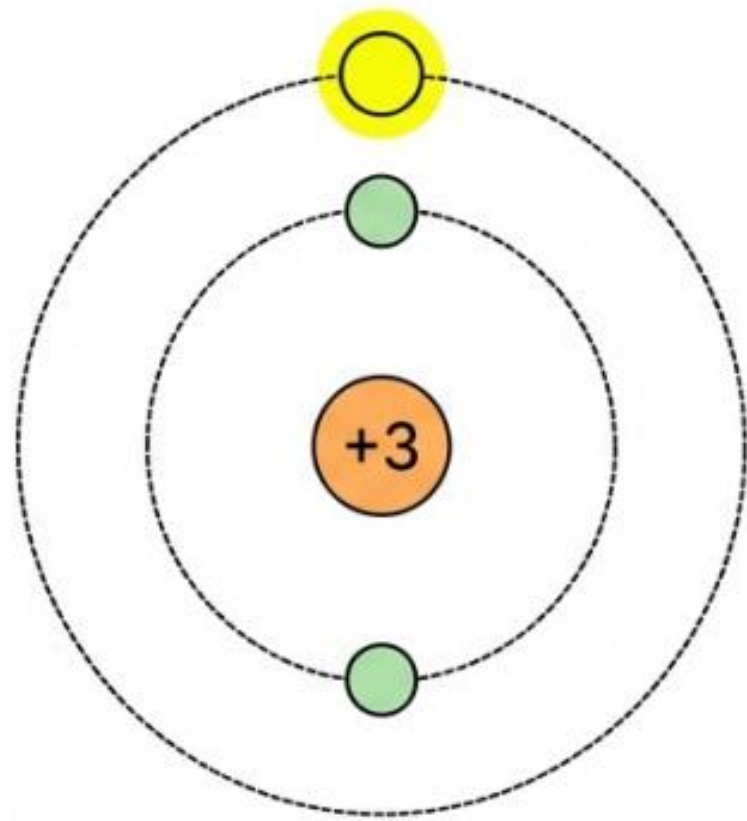

Lithium (1 Valence e-)

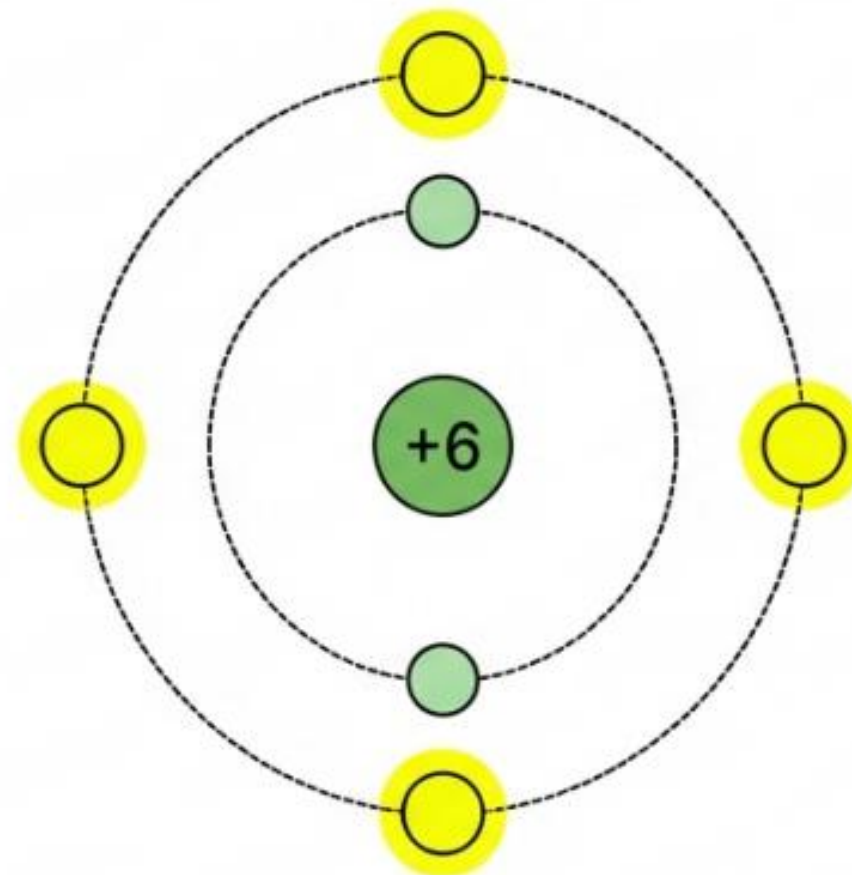

Carbon (4 Valence e-)

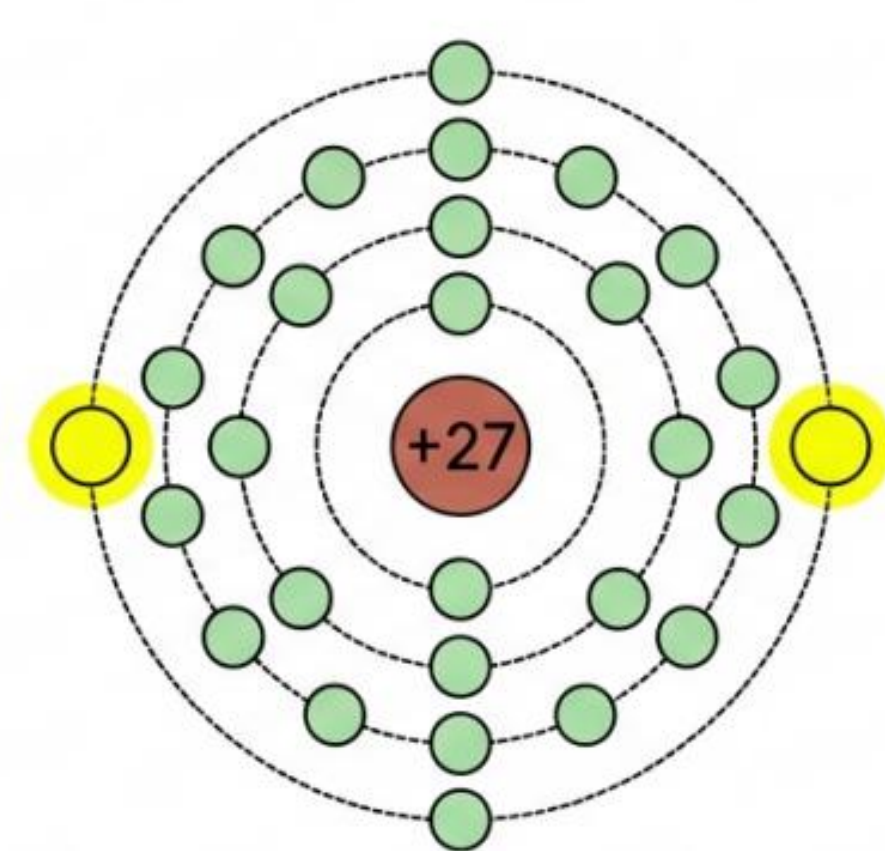

Cobalt (2 Valence e-)

**Valence Electrons:** The electrons in the outermost shell determine how an atom reacts chemically.

# The Quest for Stability: Surplus vs. Deficit

**Surplus (Reducing Agent)**

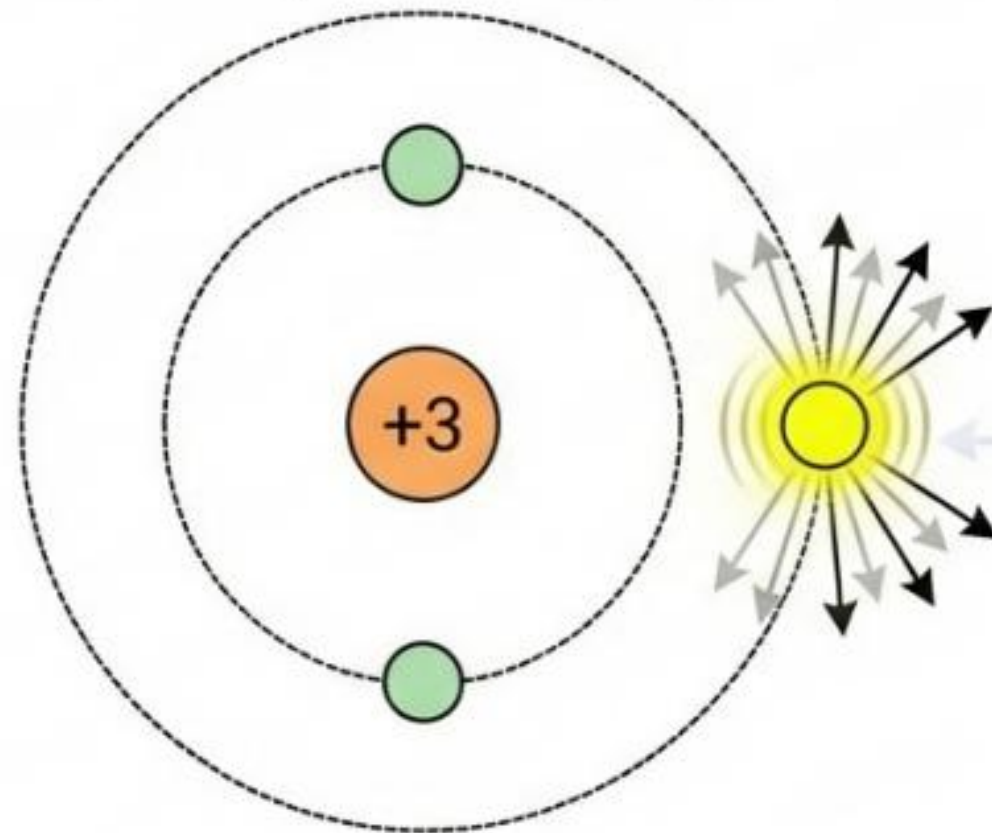

**High Reactivity:** Atoms with 1 or 2 valence electrons away from a closed shell are highly reactive.

**Surplus:** Alkali metals have one extra electron. Easily removed to form positive ions.

**Deficit (Oxidizing Agent)**

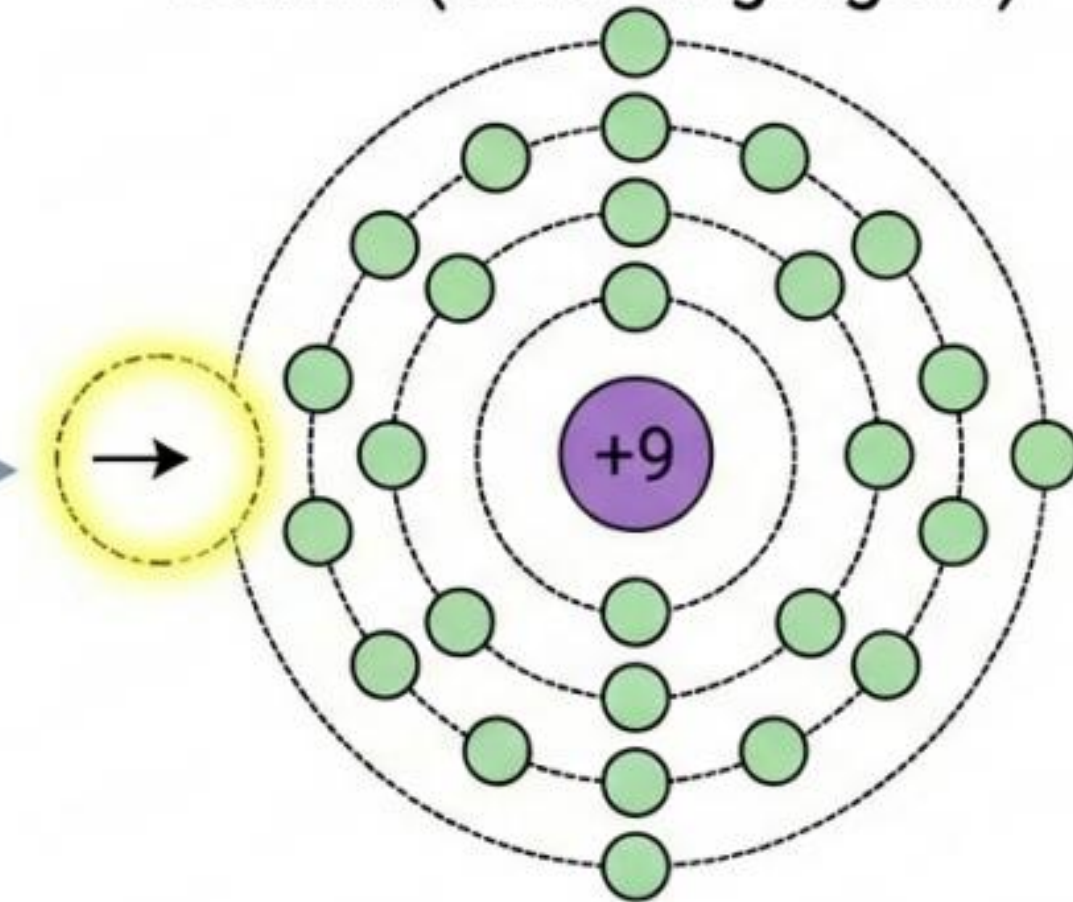

**Deficit:** Halogens are short one electron. Strong tendency to gain the missing piece.

# Oxidizing Agents: The Electron Acceptors

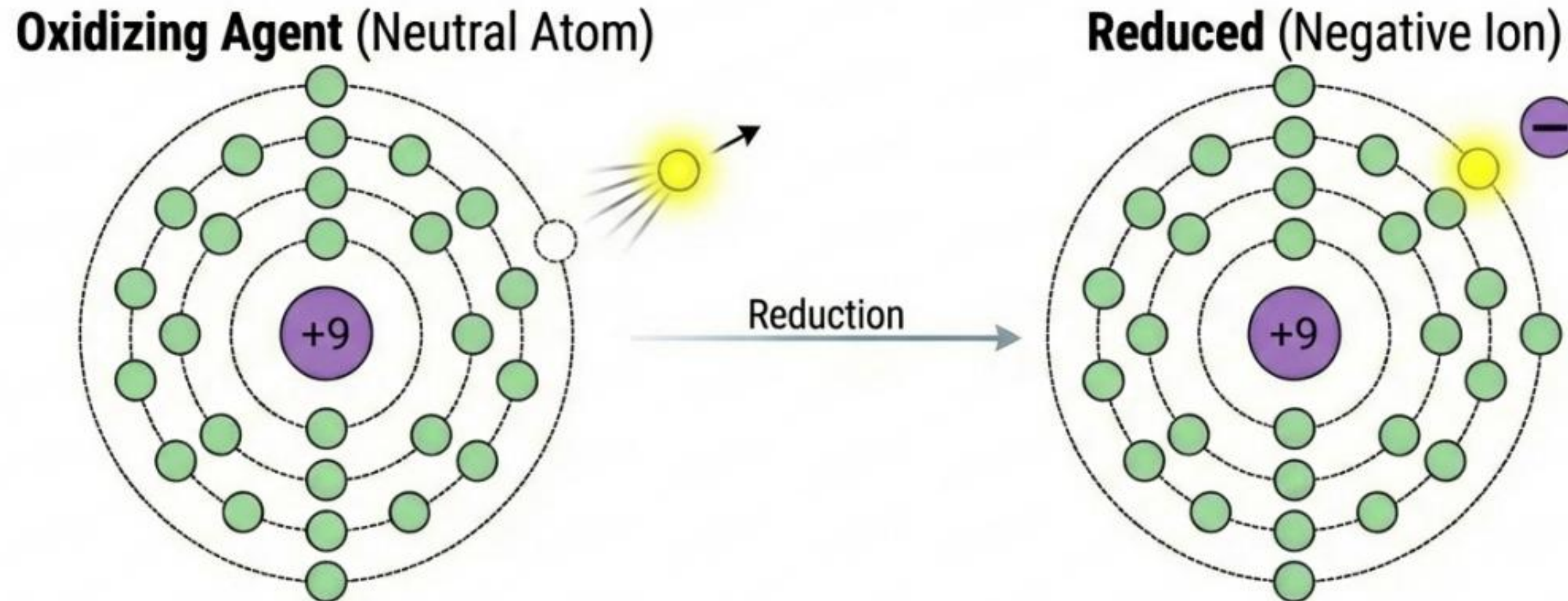

- **Oxidizing Agents:** Elements with a deficit of valence-shell electrons.
- **The Action:** They **ACCEPT** electrons in a redox reaction.
- **The Result:** The atom becomes **Reduced** (forms a negative ion).

# Converting Chemical Potential to Electrical Energy

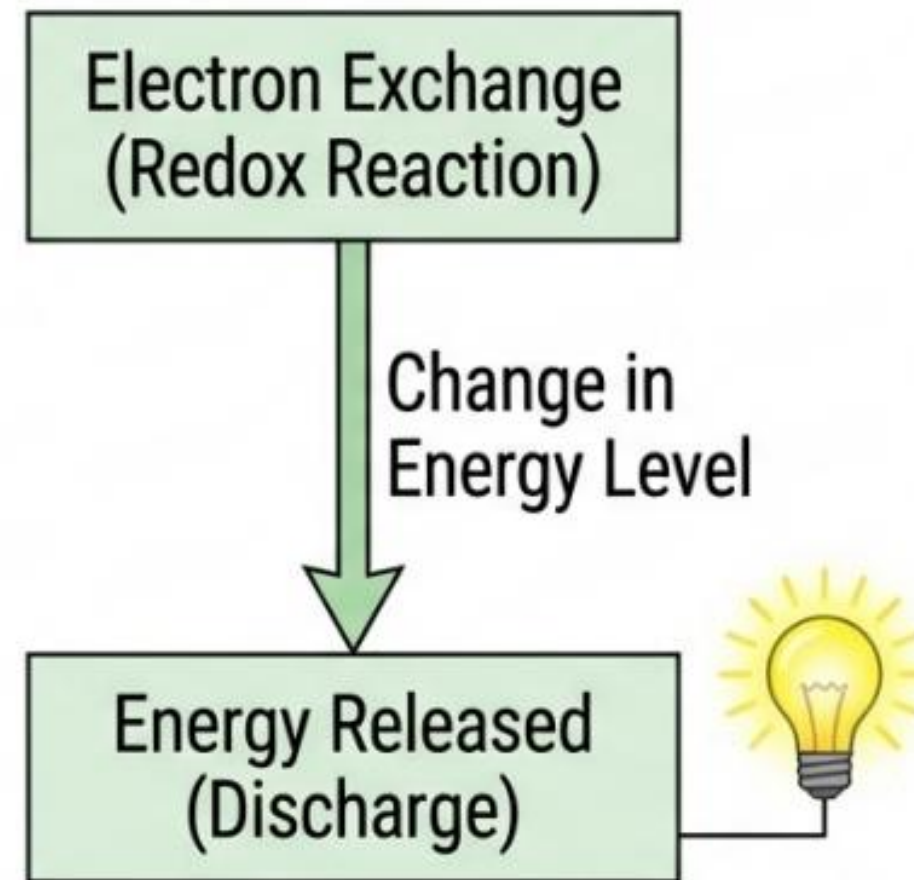

- The atom's energy level is changed by gaining or losing electrons.
- **Discharge:** This change in energy is released as electrical energy to power the load.
- **Charge:** For secondary batteries, electrical energy is absorbed to reverse the process.

# The Electrochemical Series

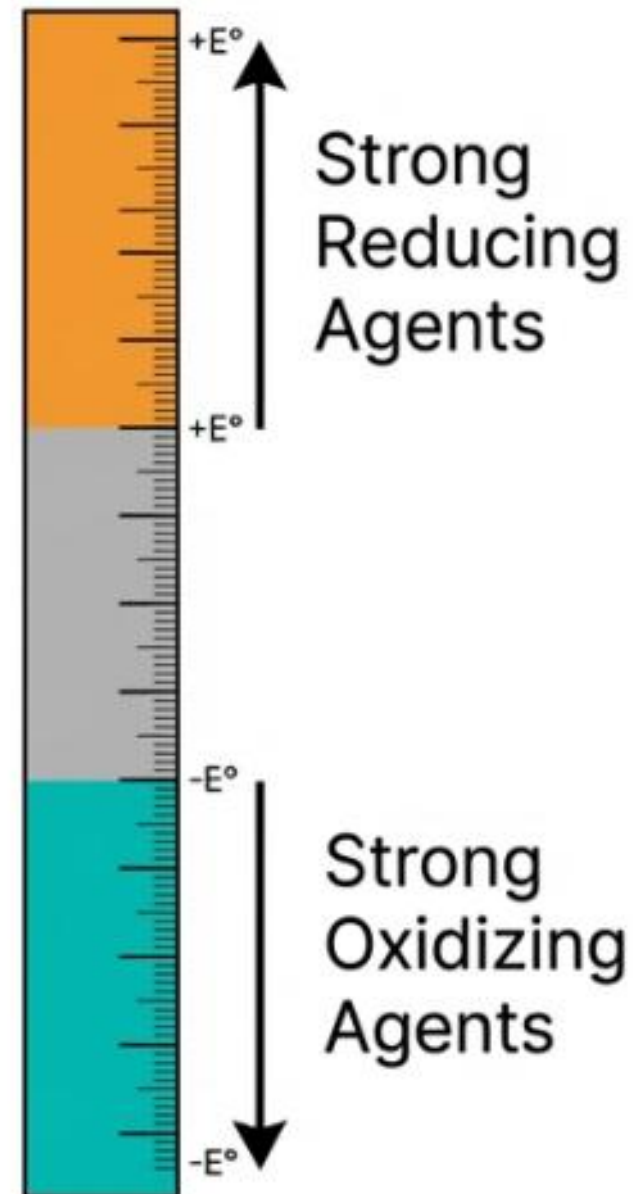

**\*\*Definition\*\*:** A list of metallic elements or ions arranged according to their electrode potentials.

**\*\*Purpose\*\*:** Allows engineers to predict the voltage a combination of materials will produce.

# Analyzing Standard Potentials

Element	Potential (V)	Note
Lithium (Li)	3.04 V	Strong Reducing ↑
Potassium (K)	2.92 V	
Sodium (Na)	2.71 V	
Hydrogen (H)	0.00 V	Baseline ⊕
Fluorine (F <sub>2</sub> )	2.87 V	Strong Oxidizing ↓

**Lithium:** Located at the extreme of the reducing agents.

**Hydrogen:** Serves as the zero-point reference (0.00 V).

**Fluorine:** Located at the extreme of the oxidizing agents.

# Maximizing Cell Voltage (EMF)

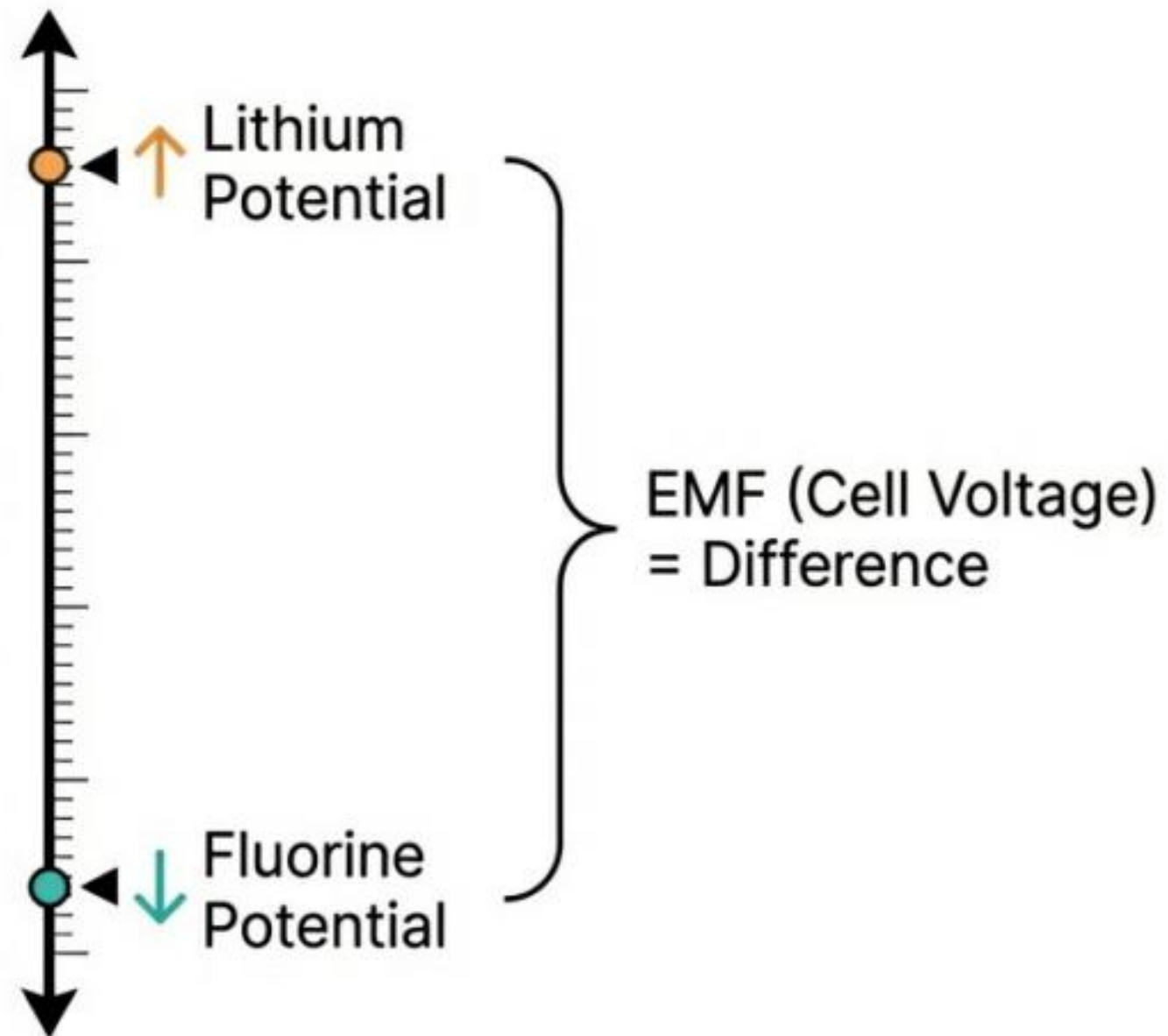

**\*\*The Principle\*\*:** The larger the difference between the electrode potentials of the two materials...

**\*\*The Result:** ...the greater the voltage (EMF) and energy density of the cell.

This explains why Lithium-ion cells are so effective—they utilize the extremes of the series.

# Maximizing Cell Voltage (EMF)

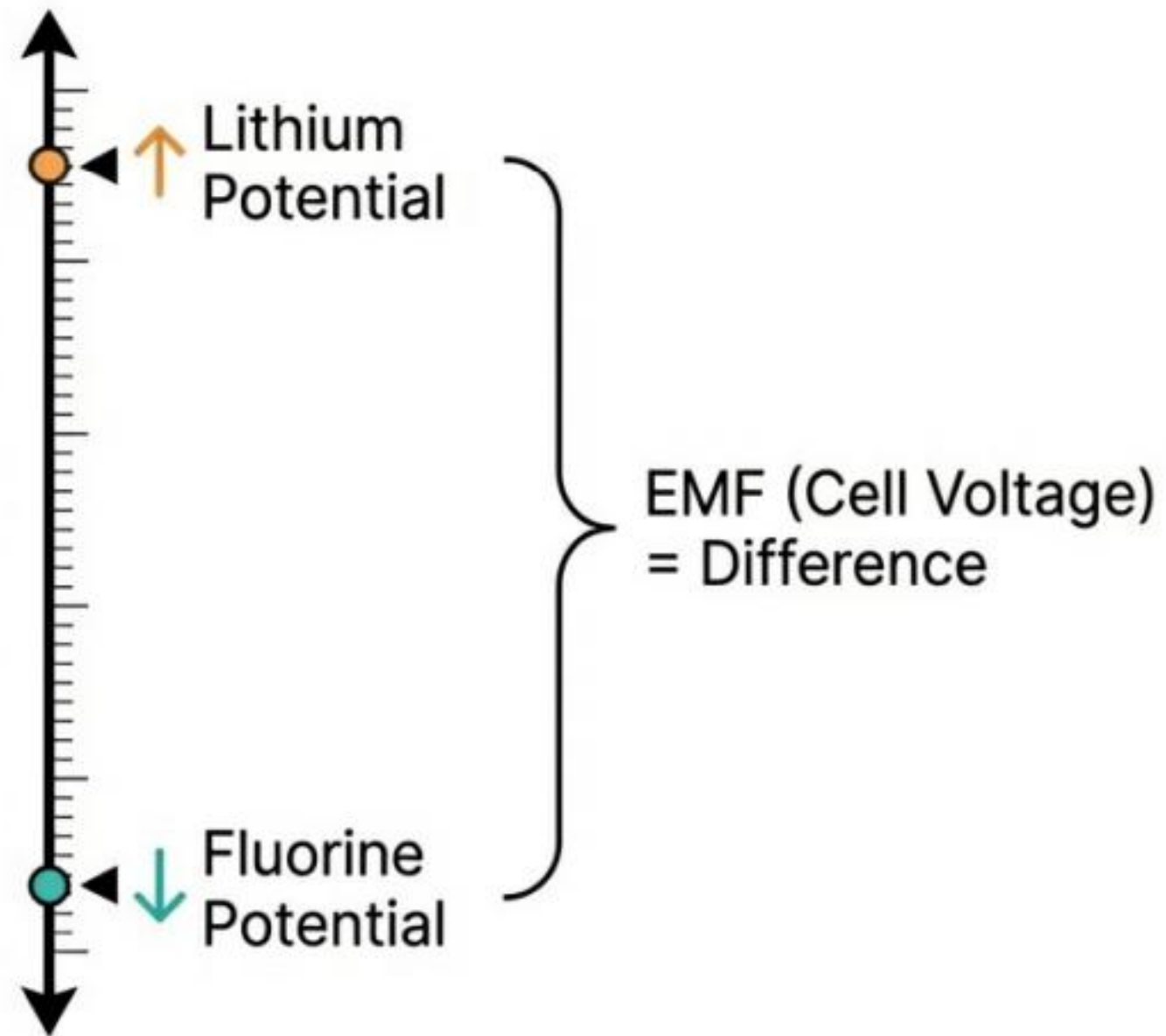

**\*\*The Principle\*\*:** The larger the difference between the electrode potentials of the two materials...

**\*\*The Result:** ...the greater the voltage (EMF) and energy density of the cell.

This explains why Lithium-ion cells are so effective—they utilize the extremes of the series.

# Summary: From Atomic Structure to Battery Power

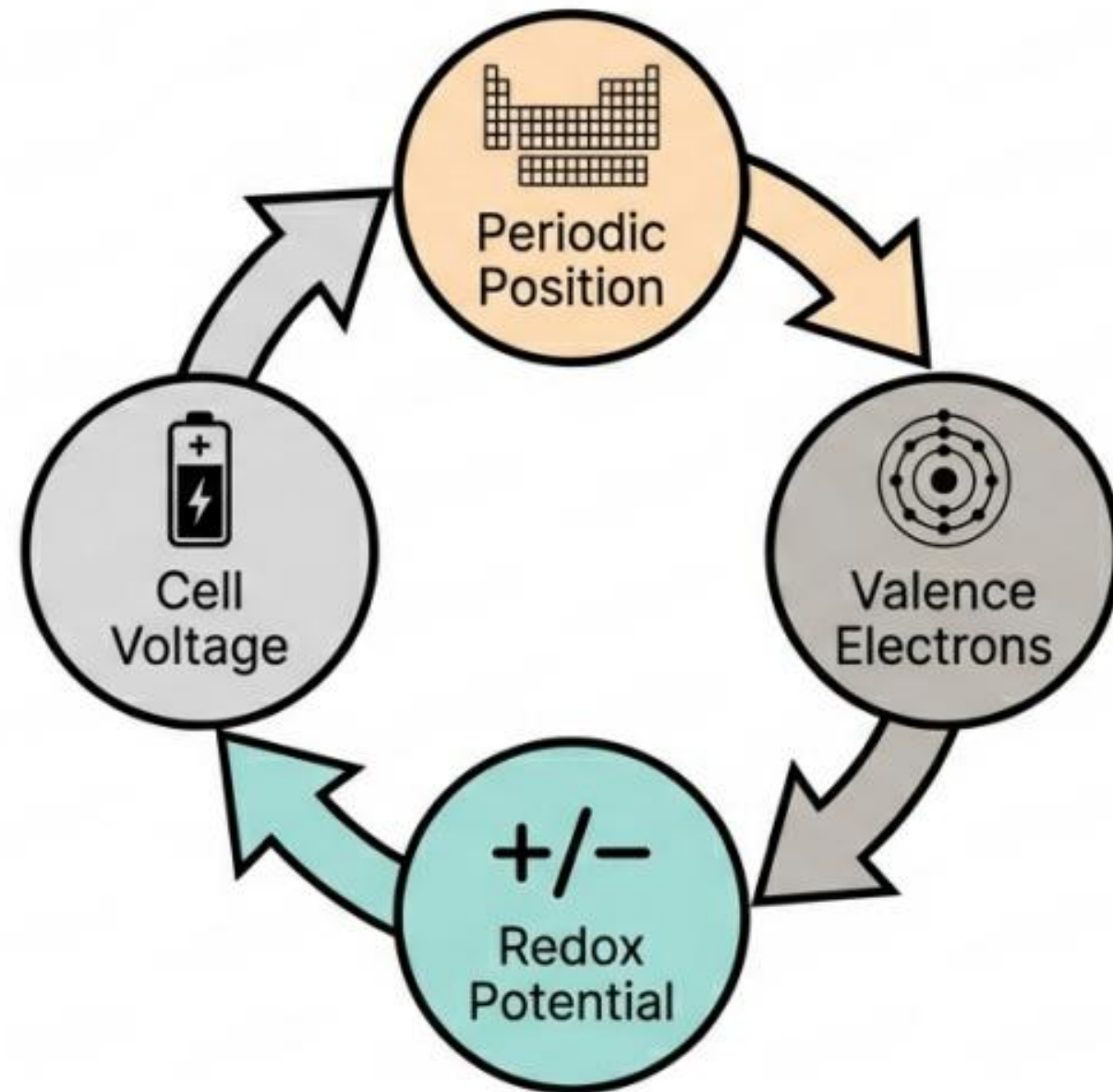

1. Materials are chosen based on their location in the Periodic Table.
2. Reactivity is driven by the desire to achieve a closed valence shell.
3. Redox reactions transfer electrons, changing energy levels.
4. Maximizing the potential difference maximizes the battery's energy.

# Battery Fundamentals

## Lithium-Ion Cell Preview

# Lithium-Ion Cell Advantages

## Voltage

A single Li-ion cell can often replace multiple NiMH or NiCd cells.

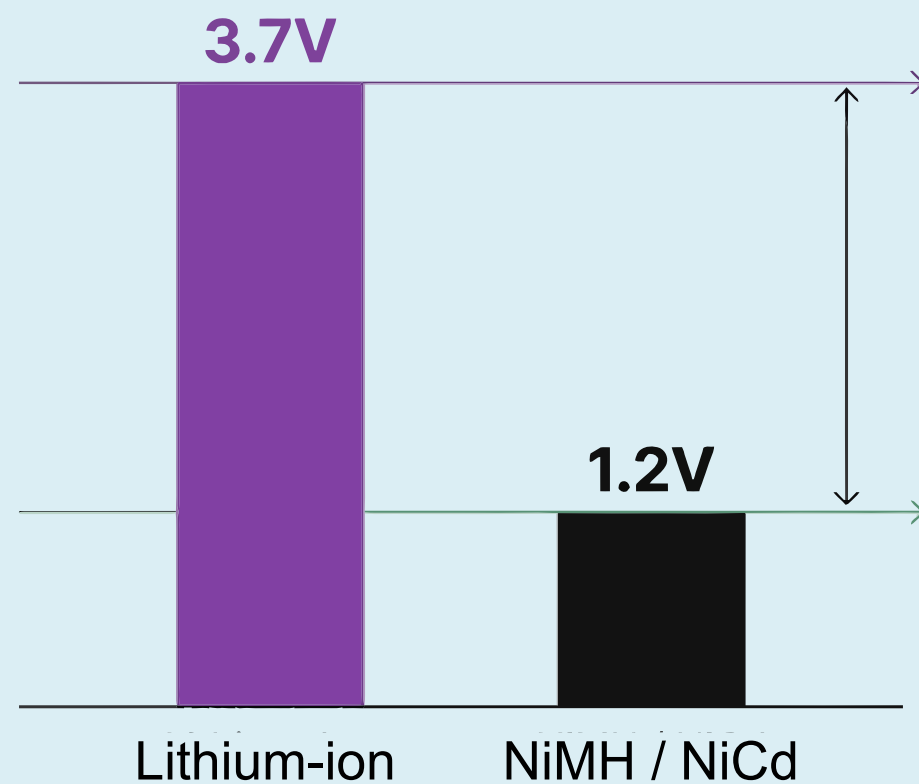

## Energy Density

Lithium-ion cells offer higher energy density than most secondary (rechargeable) cells.

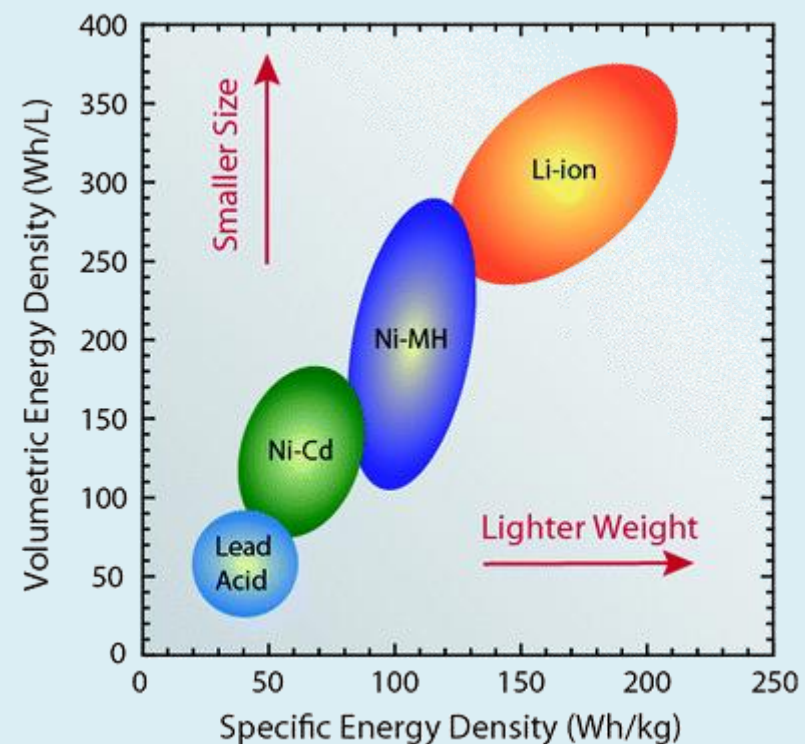

## Self-Discharge

Lithium-ion cells Retain most charge even after months of storage. While Ni-based batteries lose 1-5% charge per day when idle.

Ex: Airport Parking.

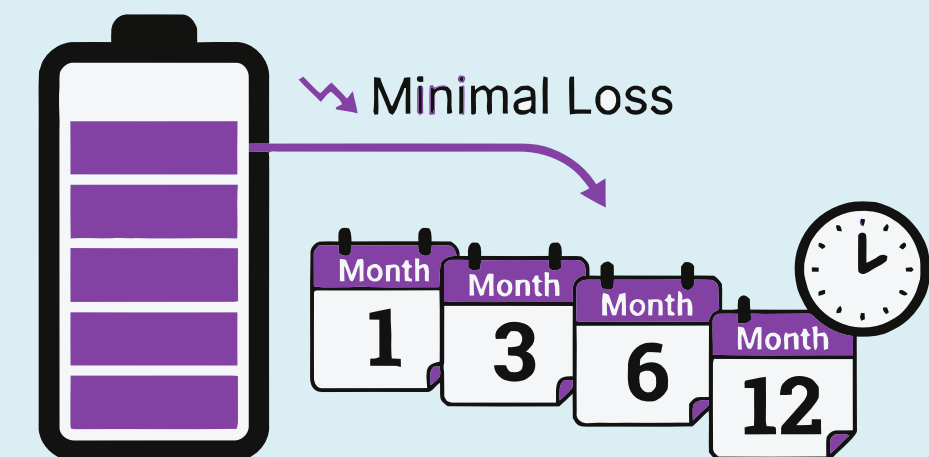

# Lithium-Ion Cell

- ❑ Lithium-ion cells work differently from the electrochemical cells: Rather than a **redox reaction**, they depend on an “**intercalation**” mechanism.
- ❑ This involves the insertion of lithium ions into the crystalline lattice of the host electrode **without changing its crystal structure**.
- ❑ These electrodes have two key properties:
  - ✓ **Open crystal structures**, which allow the insertion or extraction of lithium ions in the vacant spaces (layered Crystal structures: 2D Materials),
  - ✓ The ability to accept **compensating electrons** at the same time (Potential Diff).

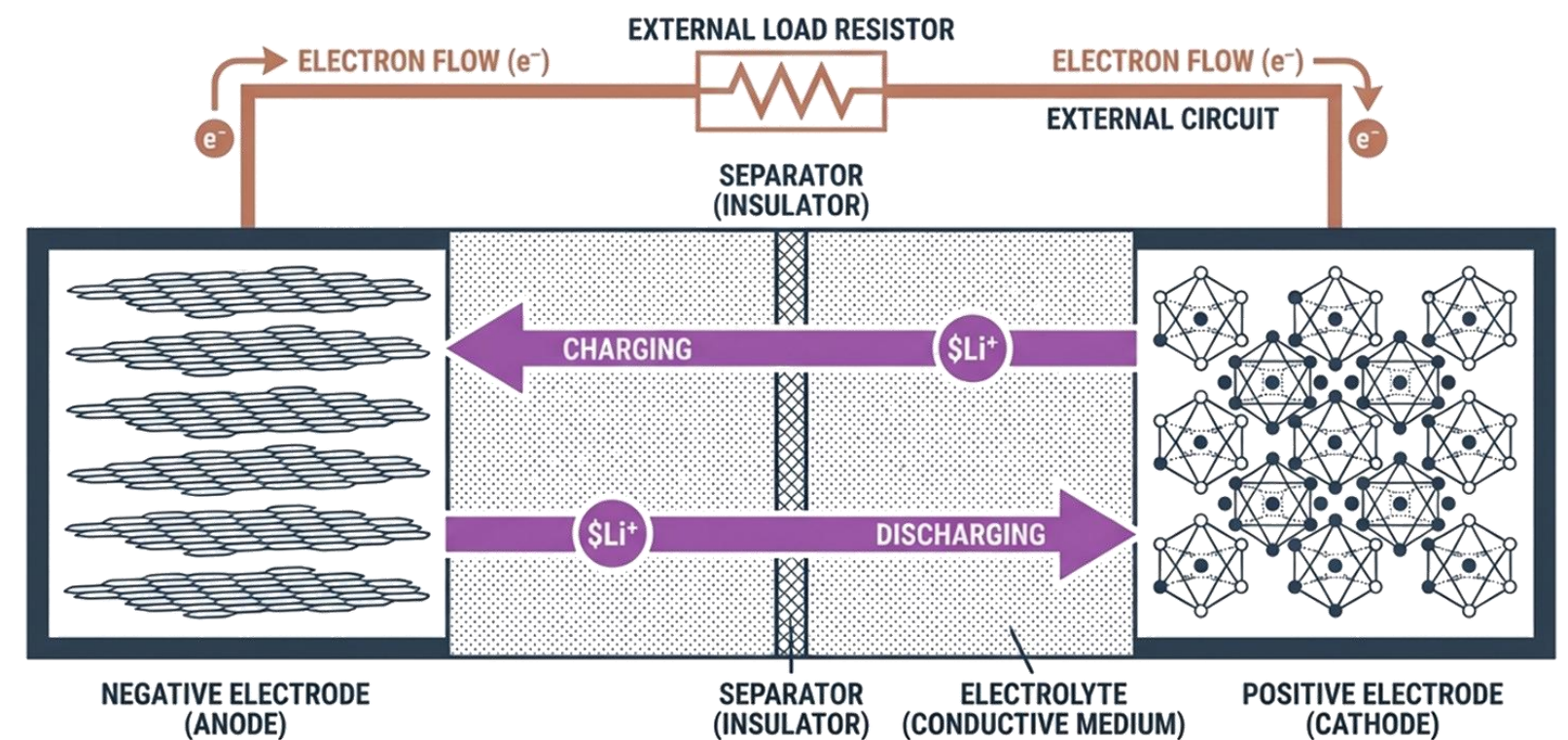

# Lithium-Ion Cell

- ❑ Lithium is stored in the electrodes much **like water is stored in a sponge**.
- ❑ Li is stored in the electrodes, and  $\text{Li}^+$  moves through the electrolyte.
- ❑  $\text{Li}^+$  enters an electrode, becoming Li when an electron is available.
- ❑ Conversely, Li exits an electrode and becomes  $\text{Li}^+$  when it can give-up an electron.
  - ✓ Within the electrode, the **lithium atom's electron is loosely shared with neighboring atoms**.
  - ✓ The lithium is **not tightly bonded** in one place and is actually **quite free to move around**.
  - ✓ Lithium **enters the surface of the electrode particles**, but diffuses inward to **equalize the concentration of lithium** in the electrode.

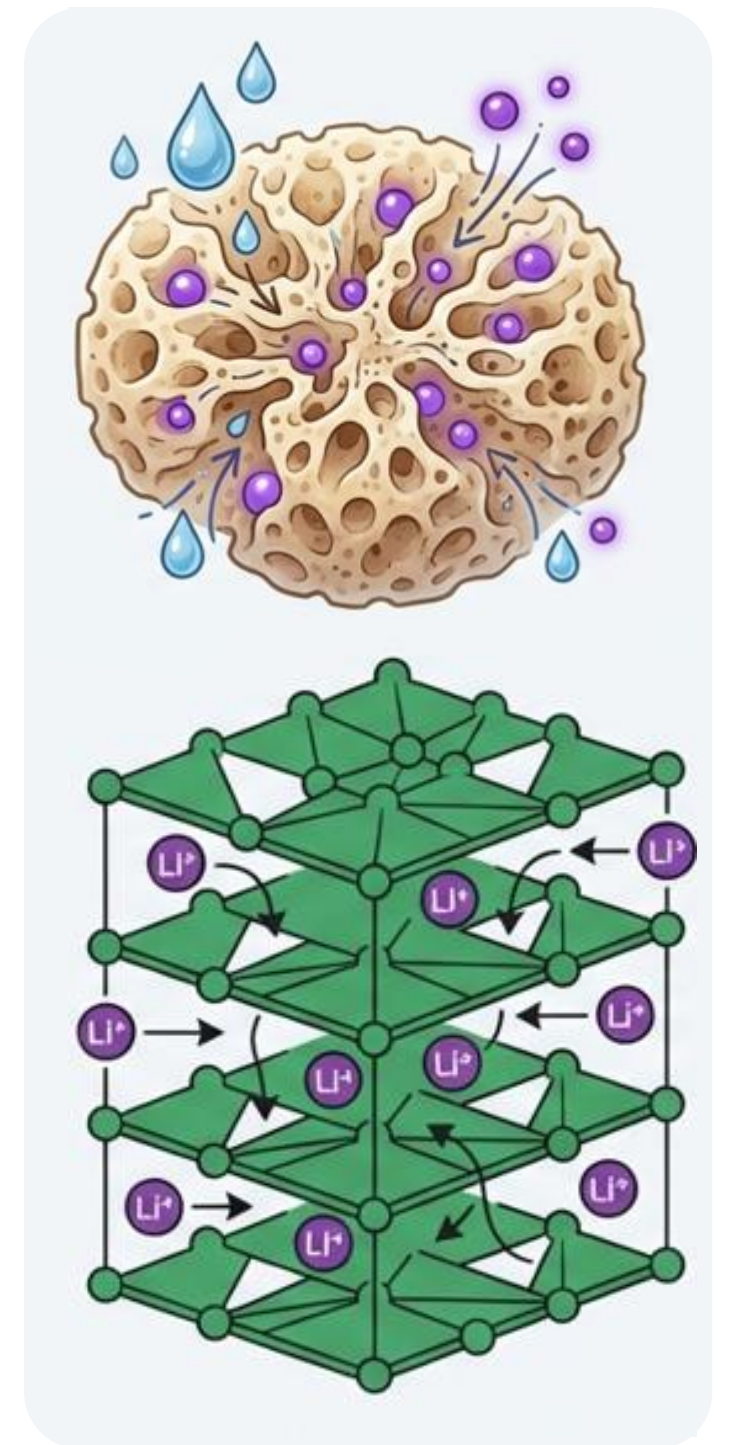

# Lithium-Ion Cell

- **During discharge,**
  - ✓ compensating **electrons** traverse the external circuit and are accepted by the positive electrode to balance the reaction.
  - ✓ Simultaneously, **lithium ions** are dissociated from the negative electrode and migrate across the electrolyte and are inserted into the crystal structure of the positive electrode.
- The process is completely reversible. Thus, the lithium ions pass back and forth between the electrodes during **charging** and **discharging**.

The **intercalation mechanism** is much gentler than an **electrochemical reaction**, so lithium-ion cells have **much longer lives** than other secondary cells.

# Li-ion Cell: Discharge Process

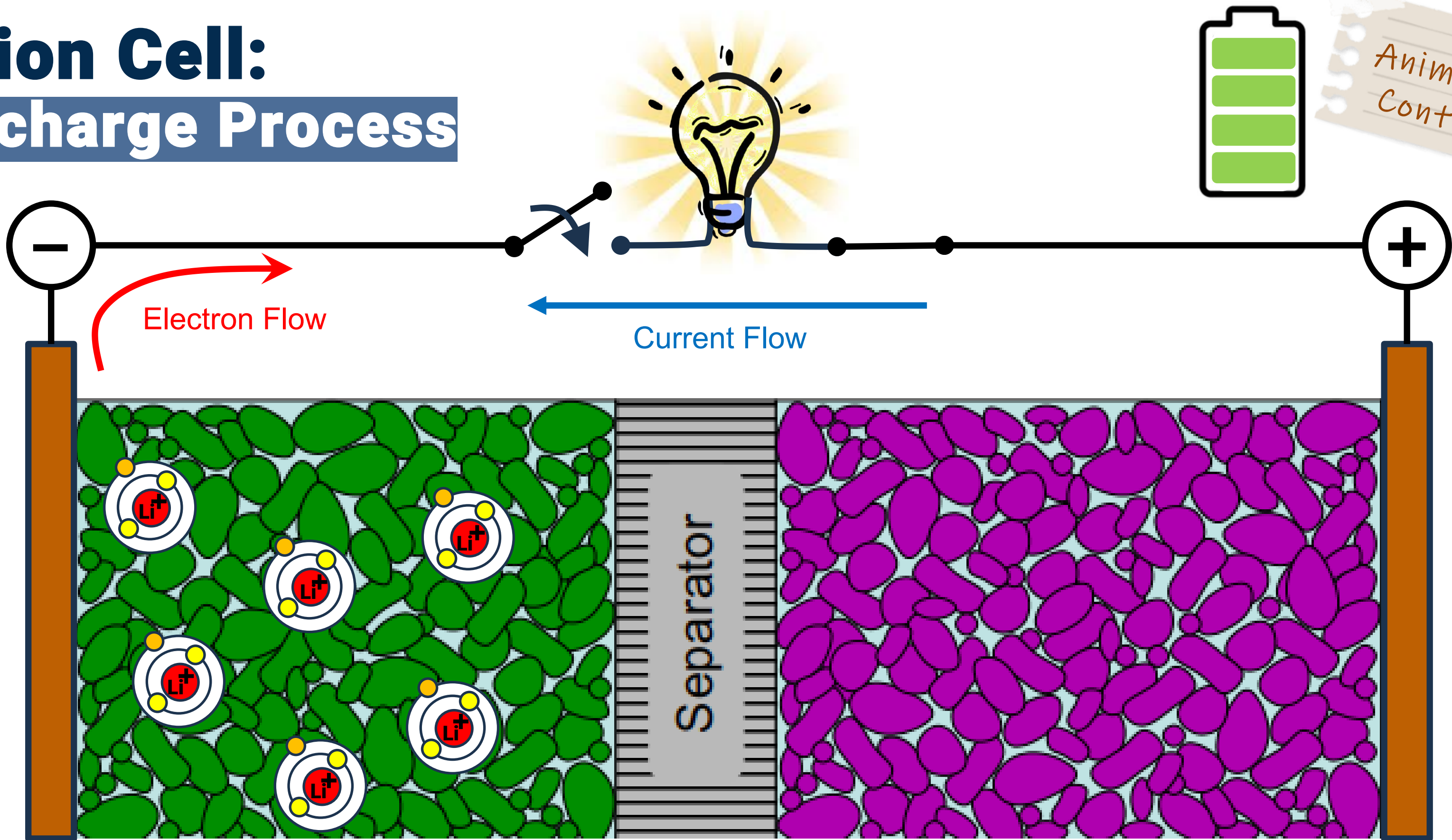

# Li-ion Cell: Charge Process

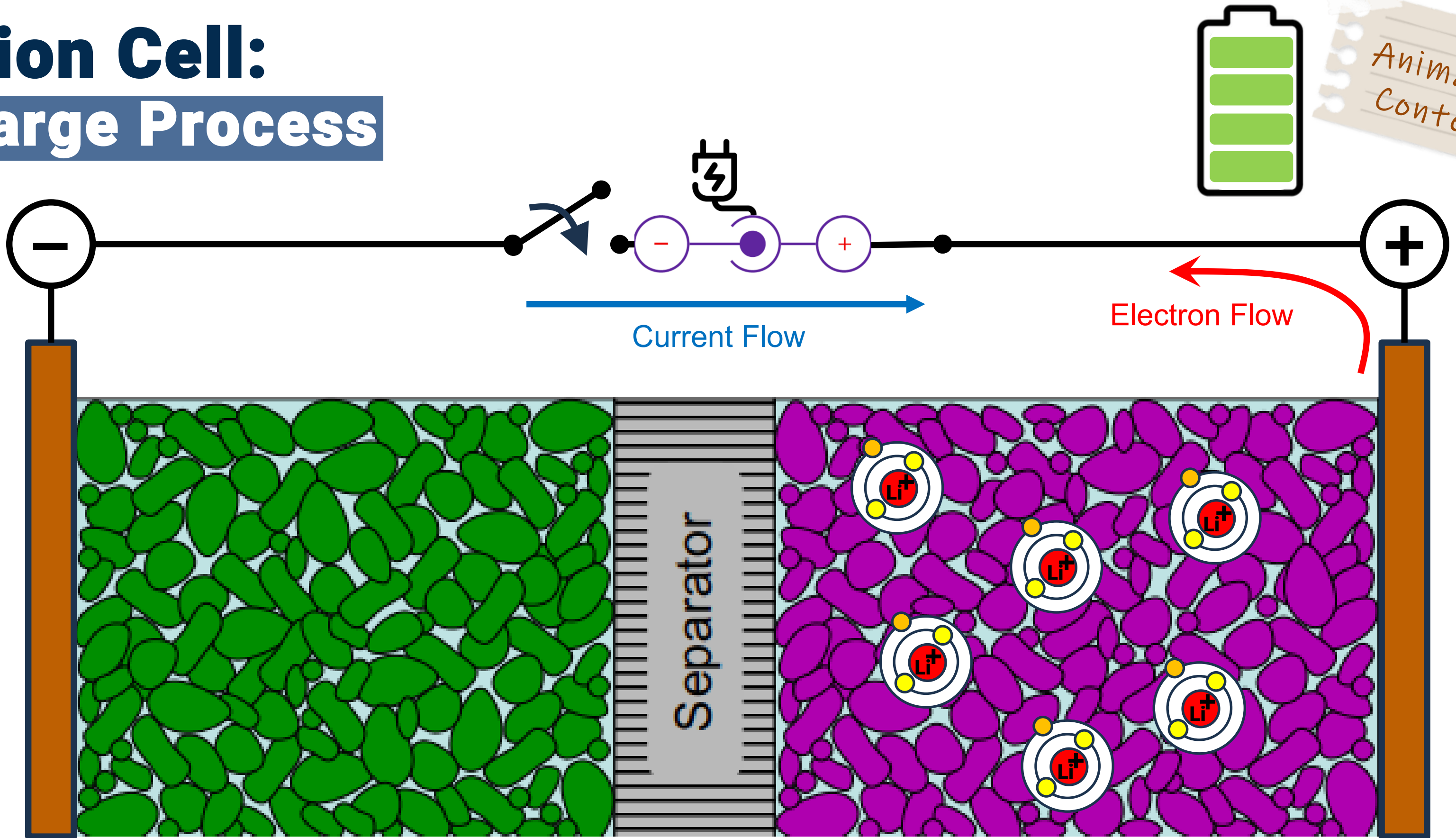

Animated Content

# Lithium-Ion Cell

- ❑ Electrodes are not homogeneous blocks, but rather millions of small particles, which:
  - ✓ Increases the surface area where reactions may occur,
  - ✓ decreasing cell resistance,
  - ✓ enhancing power delivery capability.

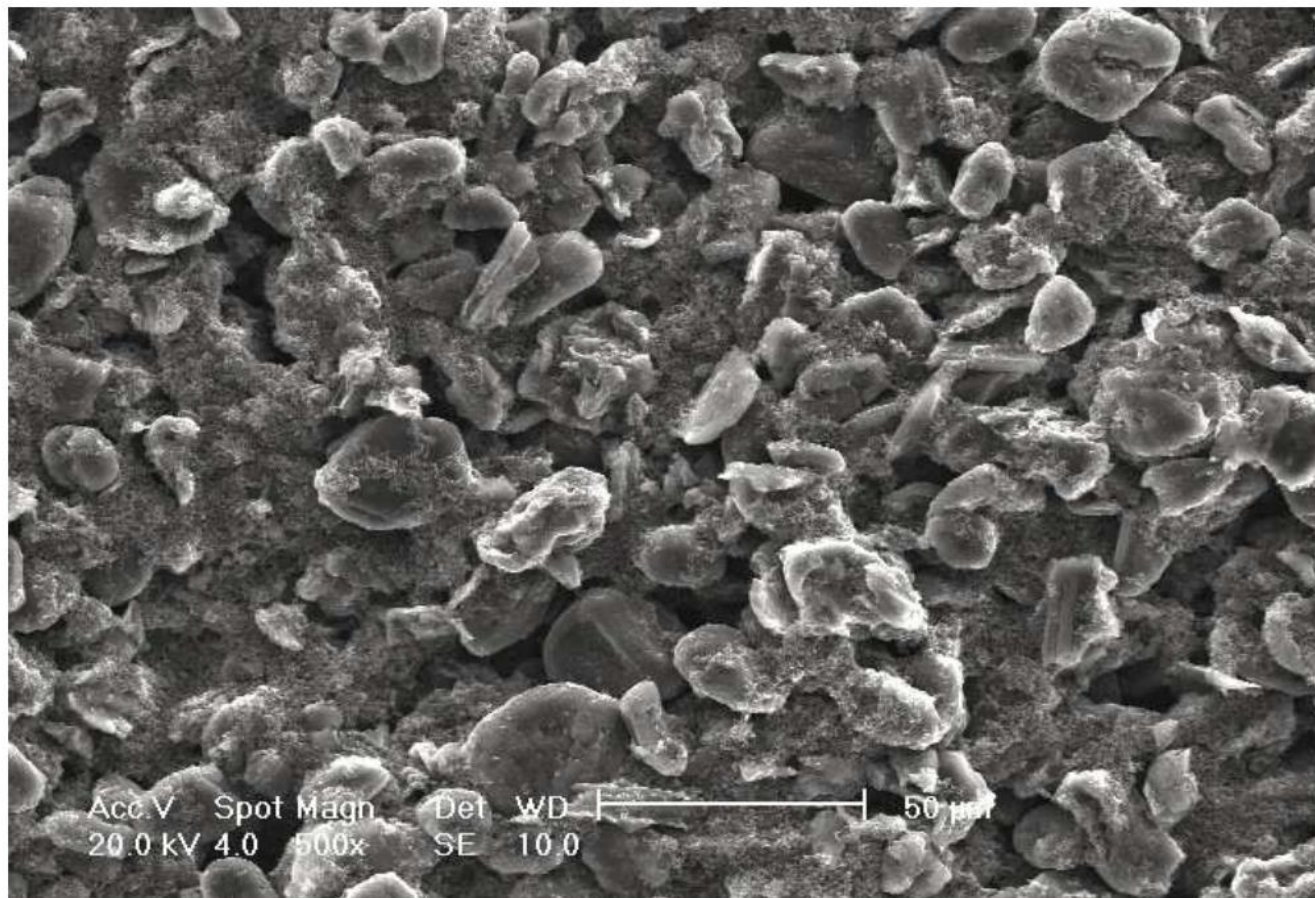

Mesophase carbonaceous spheres (graphite)

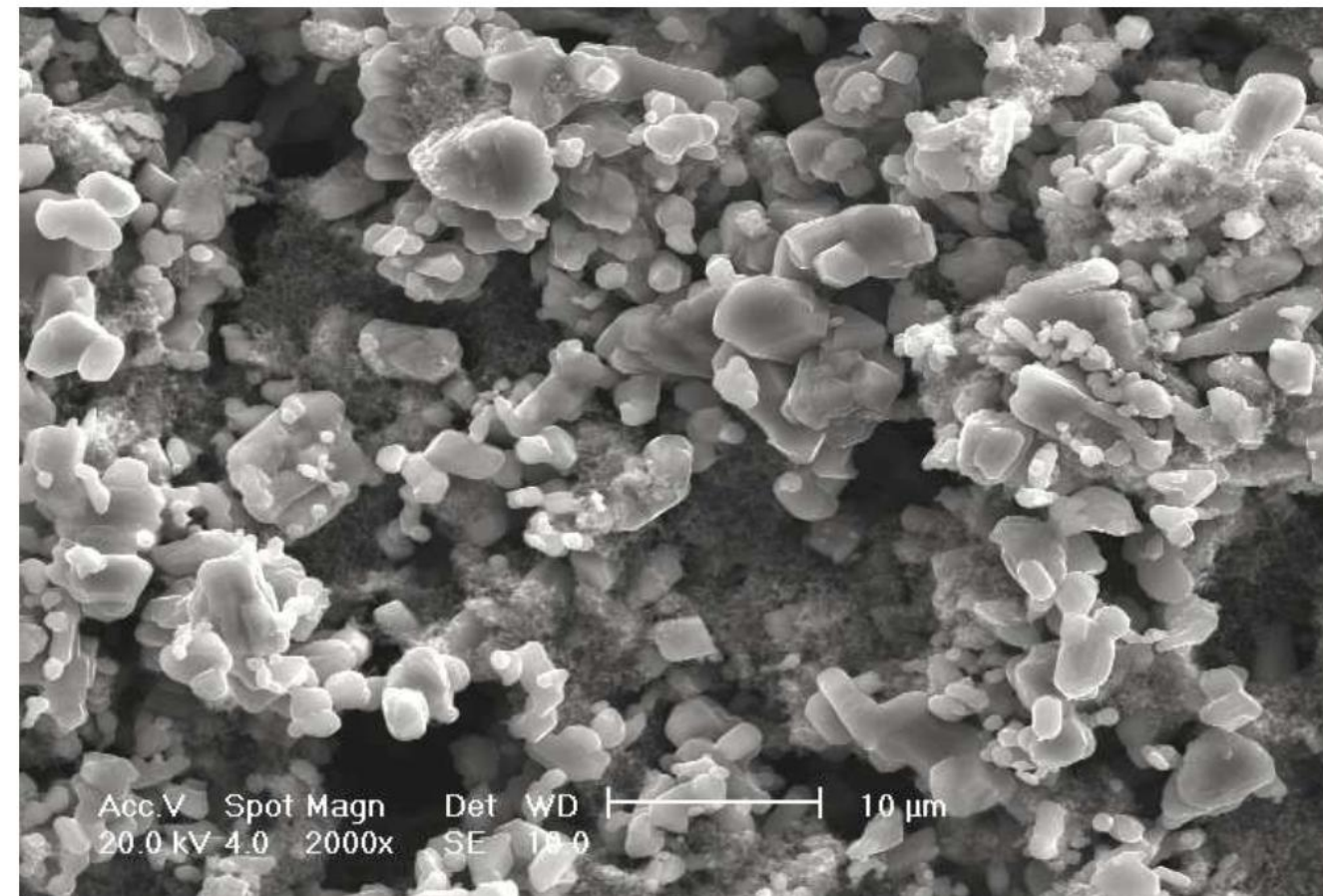

Lithium manganese oxide

# Lithium-Ion Cell

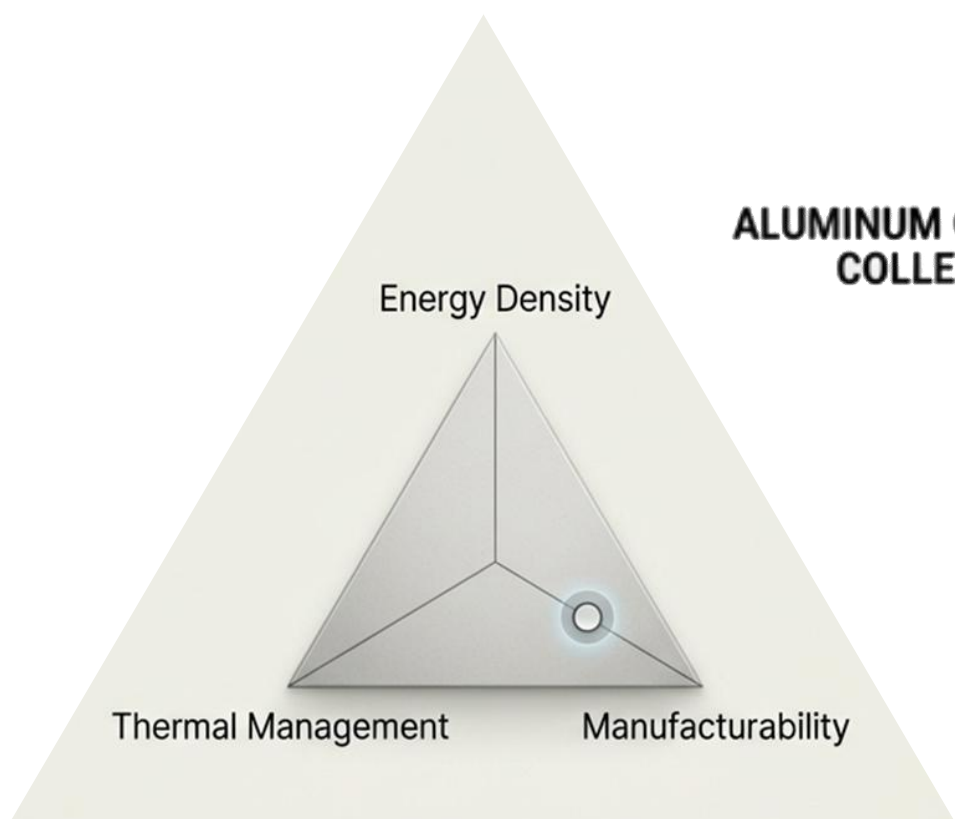
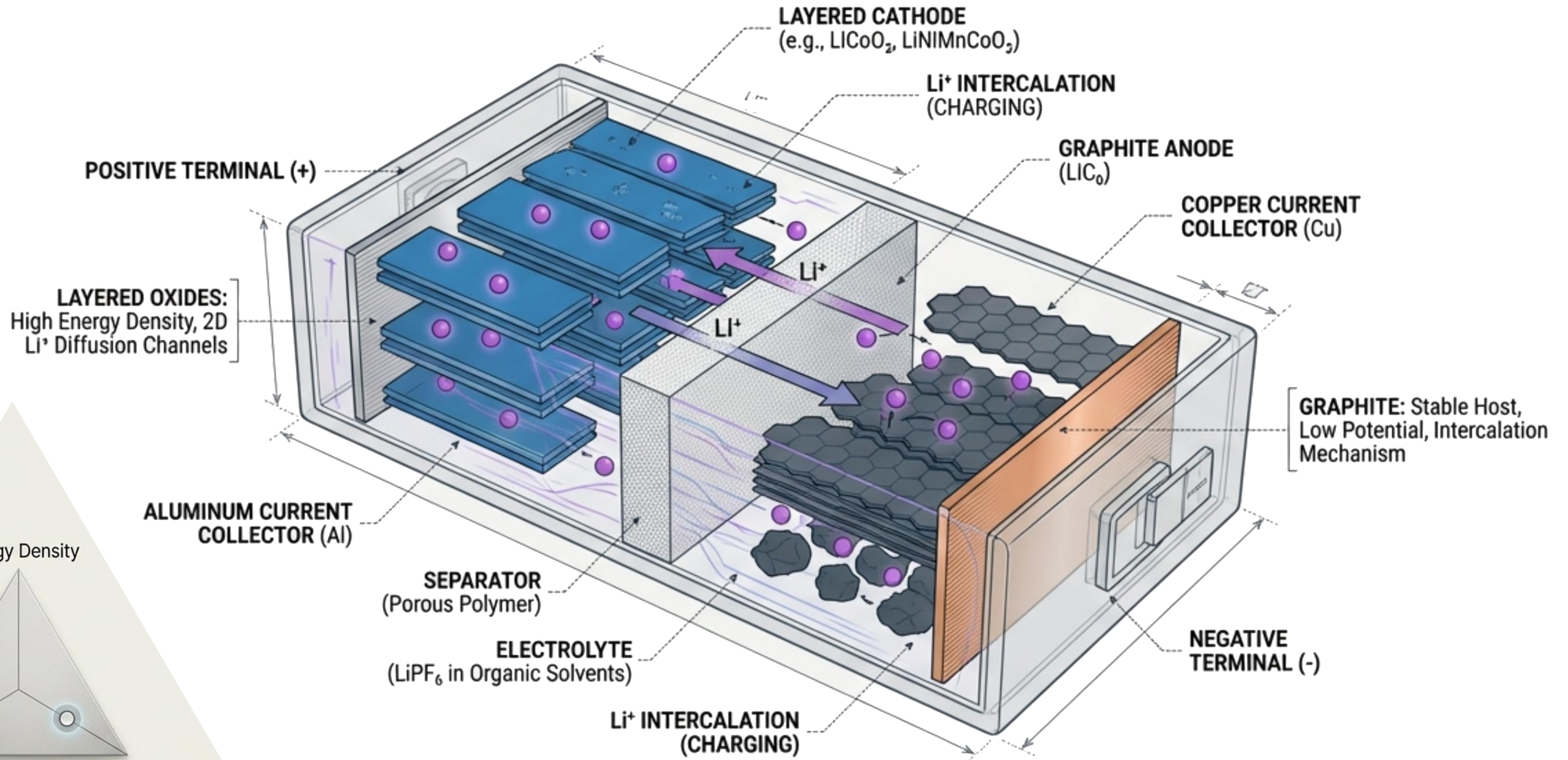

# Mechanical Assembly: Cell Form Factors

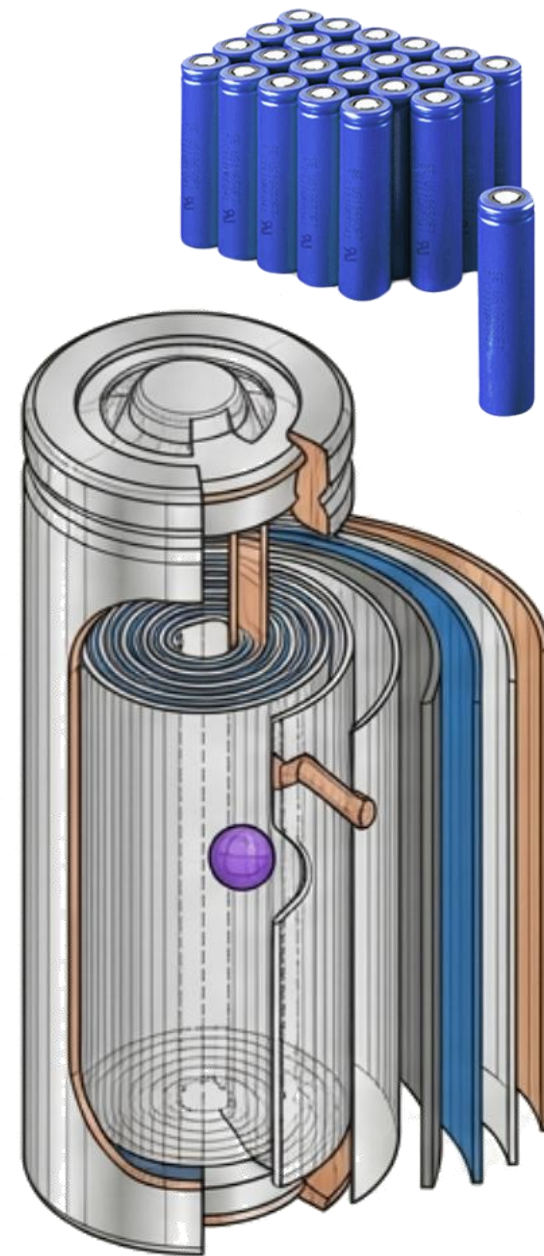

Cylindrical

Wound Construction.  
Mechanical strength.

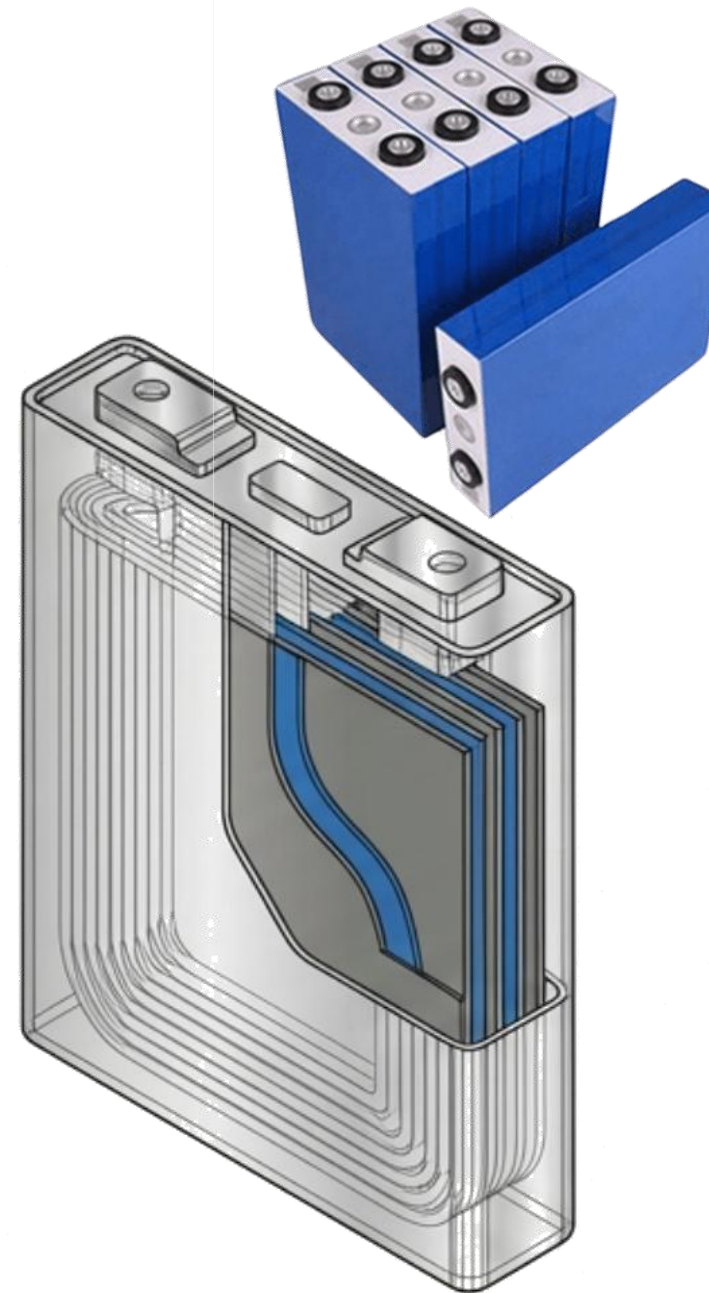

Prismatic

Wound/Stacked.  
Dense packing.

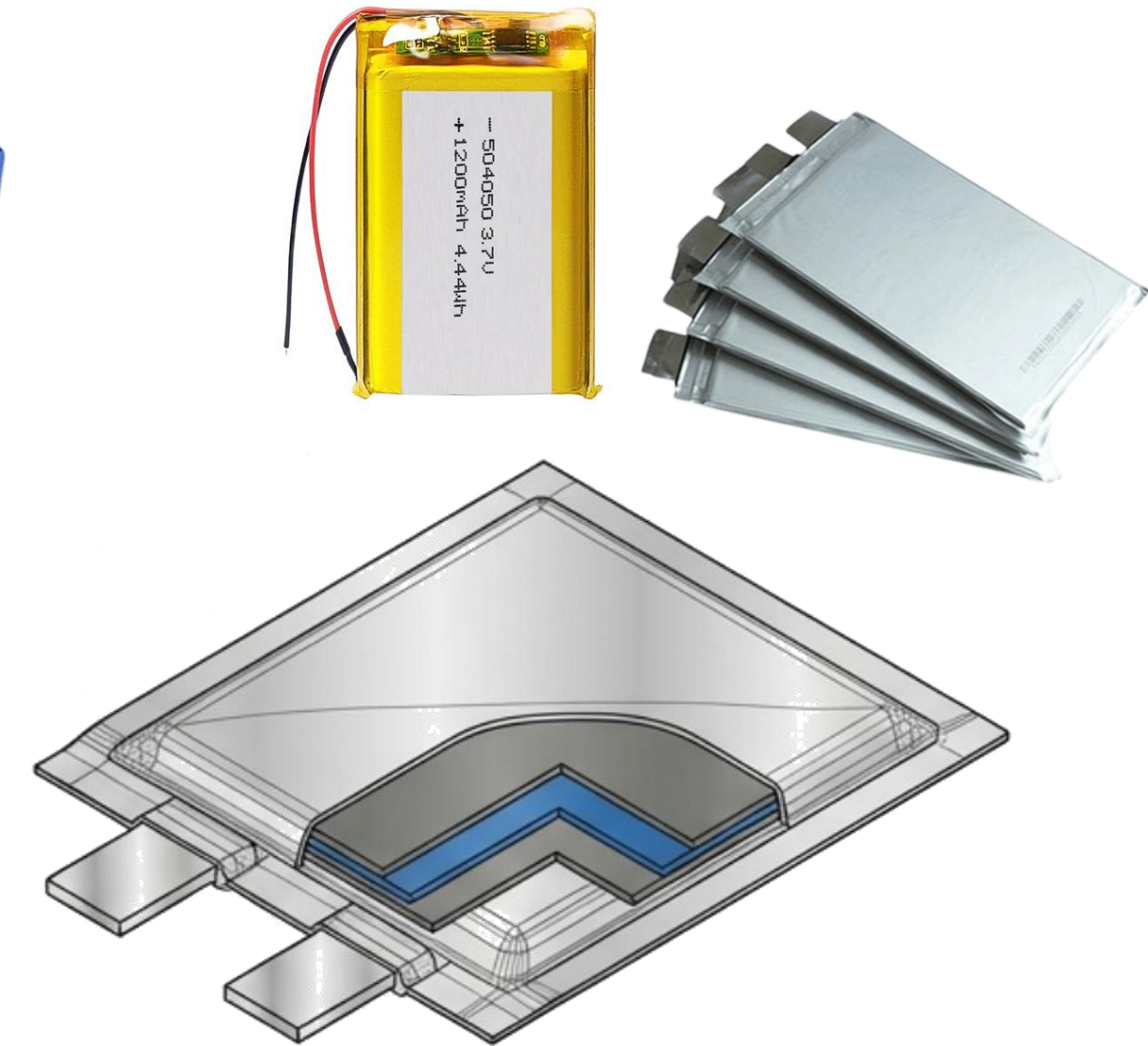

Pouch

Stacked Construction. Highest  
efficiency, needs external frame.

# Mechanical Assembly: Cell Form Factors



# Interface: Current Collectors

## Anode Collector

Stable at Low Voltage (<2V). (<2V).

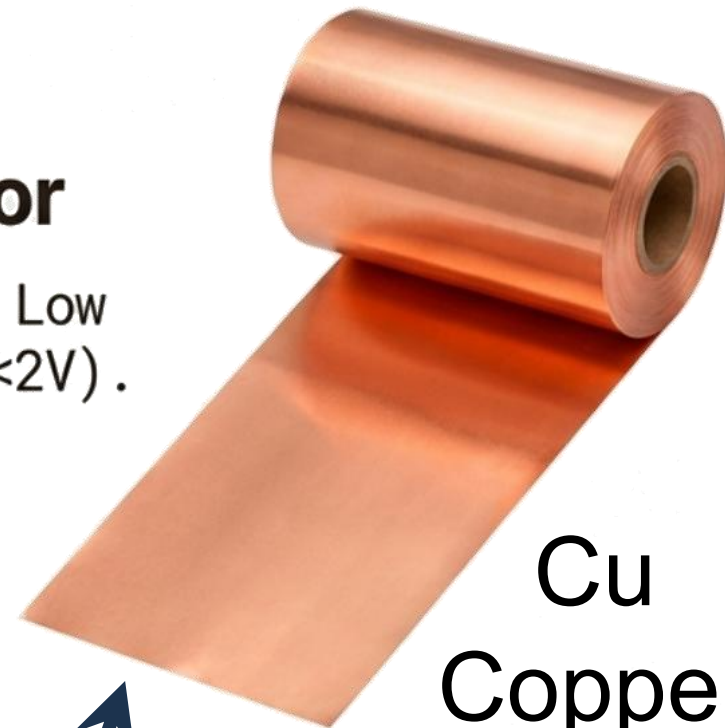

Cu  
Copper

## Cathode Collector

Stable at High Voltage (>3V). (>3V).



Al  
Aluminum

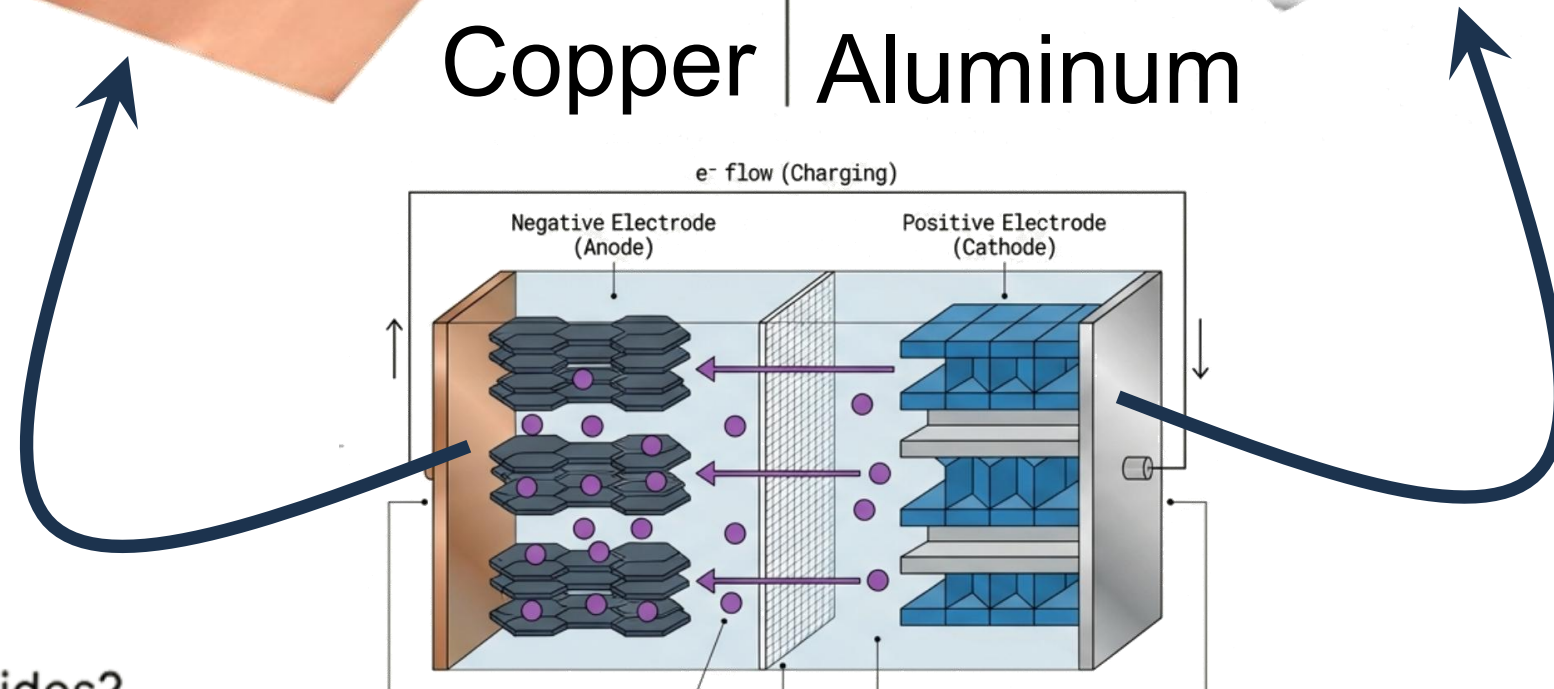

Why not use lighter Aluminum for both sides?

- **Anode Reality:** At low voltage, Aluminum reacts with Lithium, forming an alloy that crumbles to powder. **Must use Copper.**
- **Cathode Reality:** At high voltage, Copper oxidizes and dissolves. Aluminum forms a protective passivation layer. **Must use Aluminum.**

Material choice is dictated by voltage stability, not cost.

# The Anode Standard: Graphite (The Layered Host)

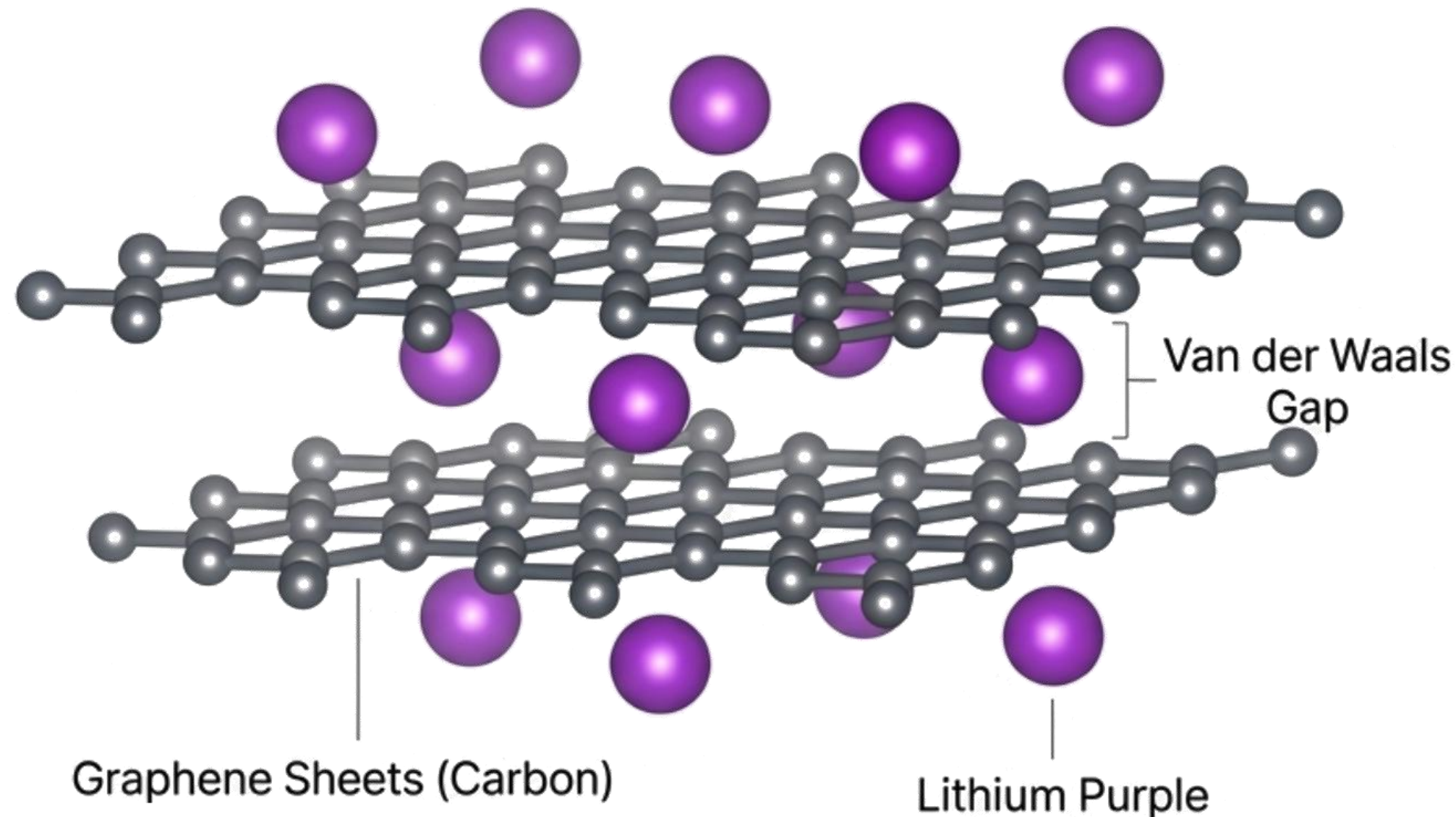

- **Structure:** Honeycomb carbon rings (Hexagonal).
- **Bonding:** Strong covalent bonds within layers; weak Van der Waals bonds between layers.
- **Stoichiometry:**  $\text{LiC}_6$  (1 Li atom per 6 Carbon atoms).
- **Mechanism:** Intercalation into the gap.
- **Voltage:**  $\sim 0.1\text{V}$  vs  $\text{Li/Li}^+$  (Low potential).

# Anode Variations: Disorder, Stability and Expansion

## 1. Synthetic Graphite

Roboto Mono

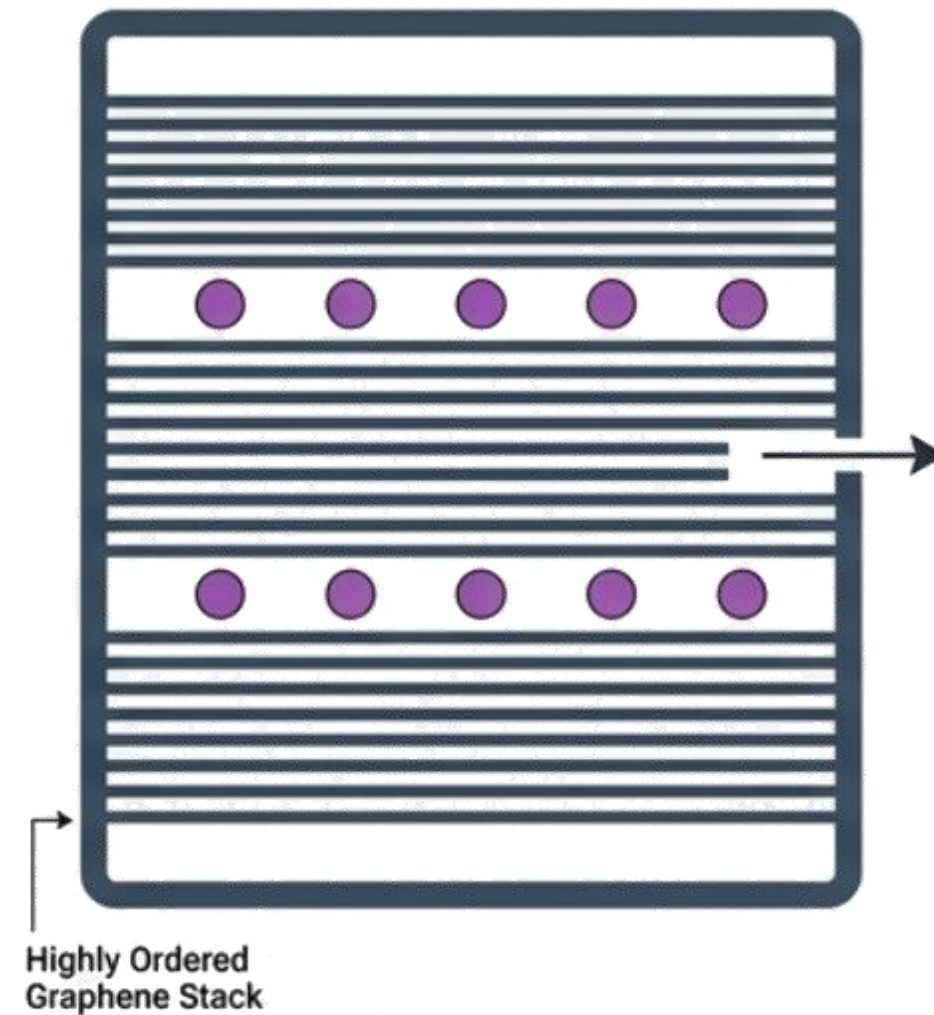

Aligned Grains  
(High Energy)

## 2. Hard Carbon

Roboto Mono

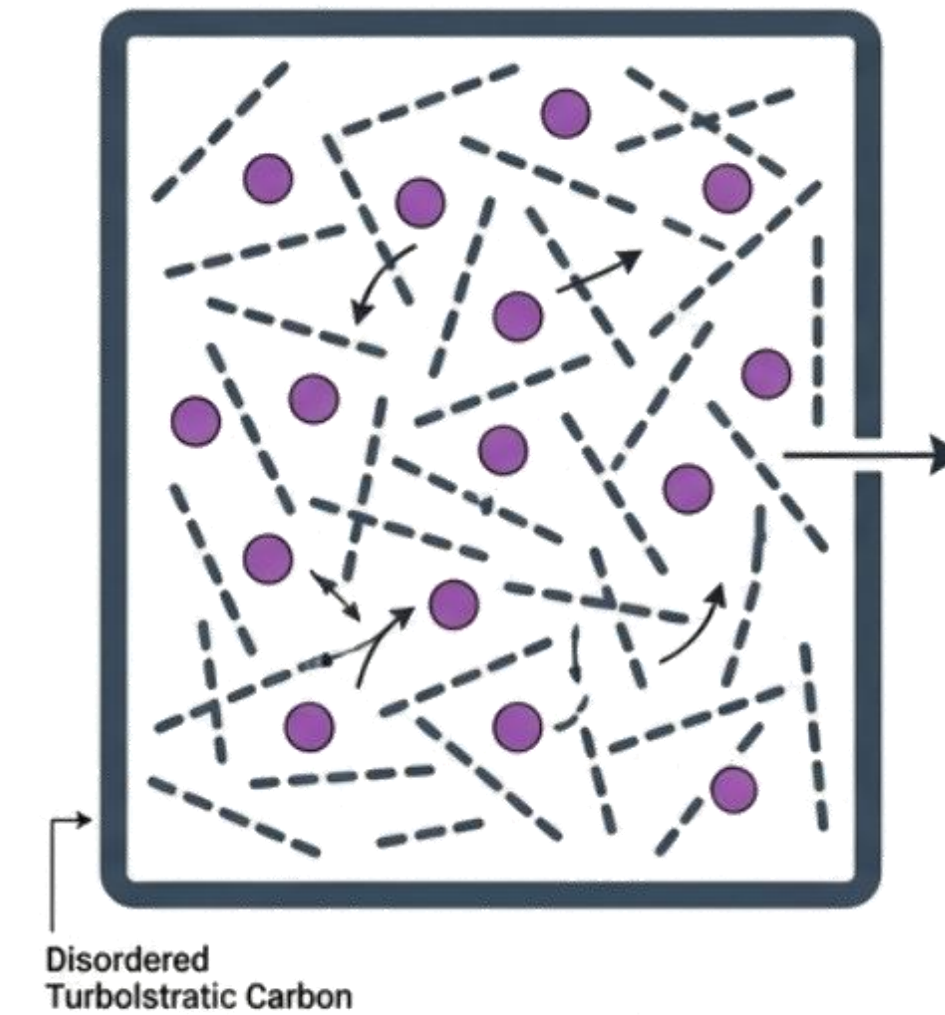

Random Orientation  
(High Power/Cost)

## 3. The Extremes: LTO vs Silicon

Roboto Mono

(A) LTO (Lithium Titanate): Zero-Strain  
(10k+ cycles), Low Energy.

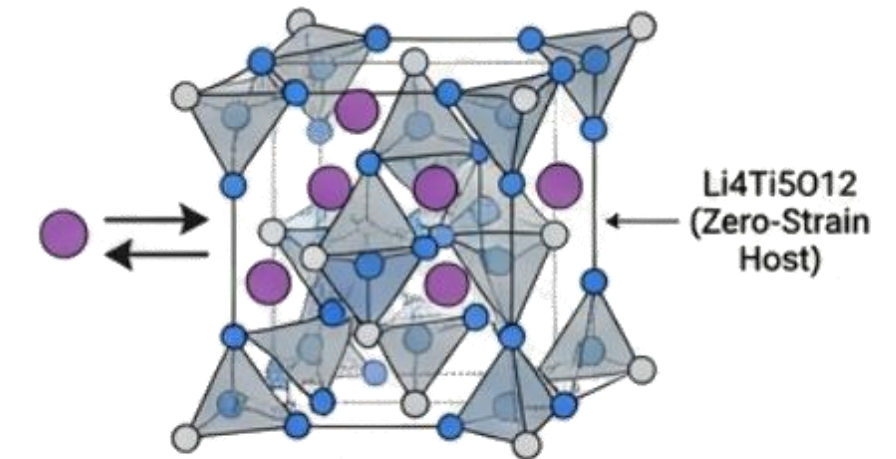

(B) Silicon: Fracture Risk.

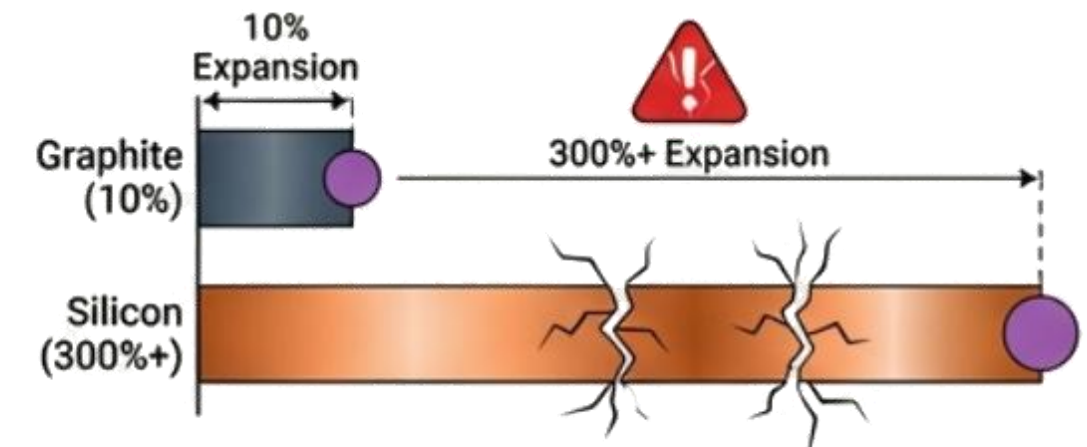

Massive Volume Change Causes Mechanical Failure.

# Lithium-ion cell makeup: Negative electrodes

Notes

- ❑ Most commercial Li-ion batteries employ **graphite-based ( $C_6$ )** materials as the negative electrode.
- ❑ Graphite consists of **layered graphene** sheets held together **by weak van der Waals forces**.
- ❑ These stacked layers create **interlayer spaces** that enable **lithium-ion intercalation**.
- ❑ During charging, lithium ions reversibly insert between graphene layers to form  $LiC_6$ .
- ❑ Both **natural and synthetic graphite** are used, offering different particle morphology and electrochemical performance.
- ❑ In some commercial systems, alternative anode materials such as **silicon-graphite composites** or **lithium titanate ( $Li_4Ti_5O_{12}$ )** are also utilized.

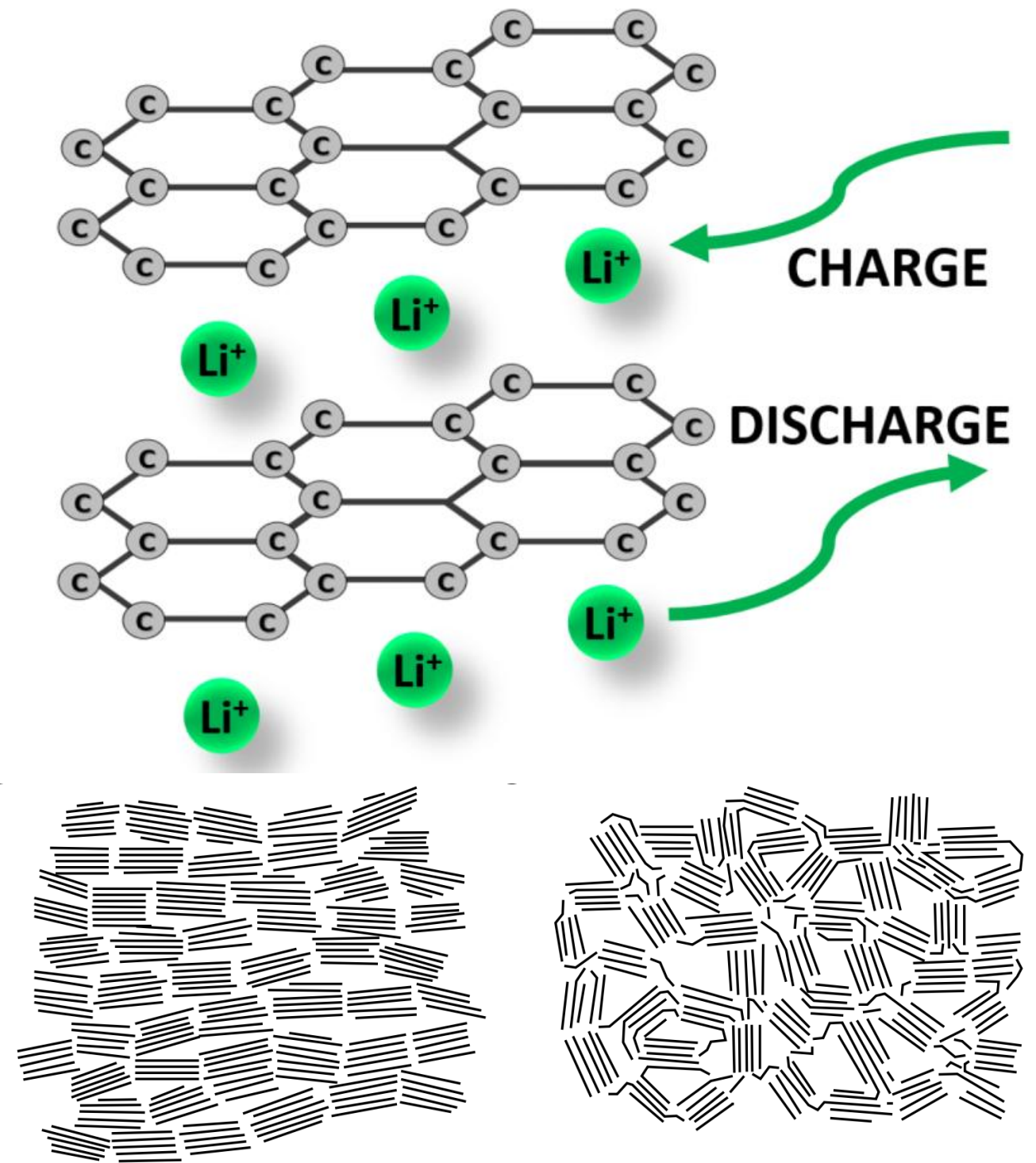

# Classifying Cathodes By Diffusion Pathway

1D Diffusion (Olivine)

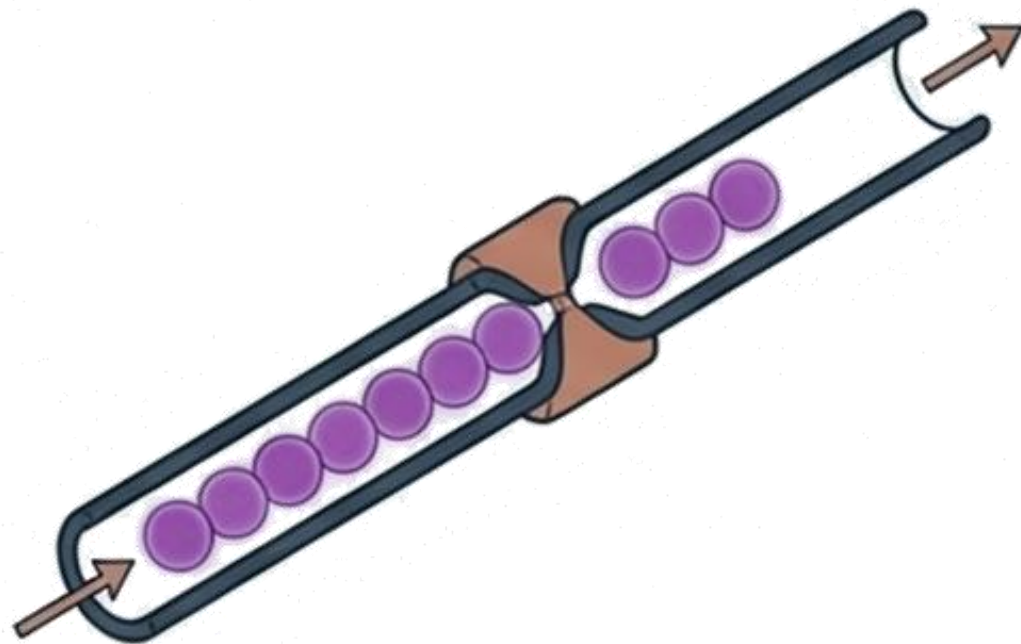

High Impedance. Single-lane traffic; blockage stops flow.

2D Diffusion (Layered)

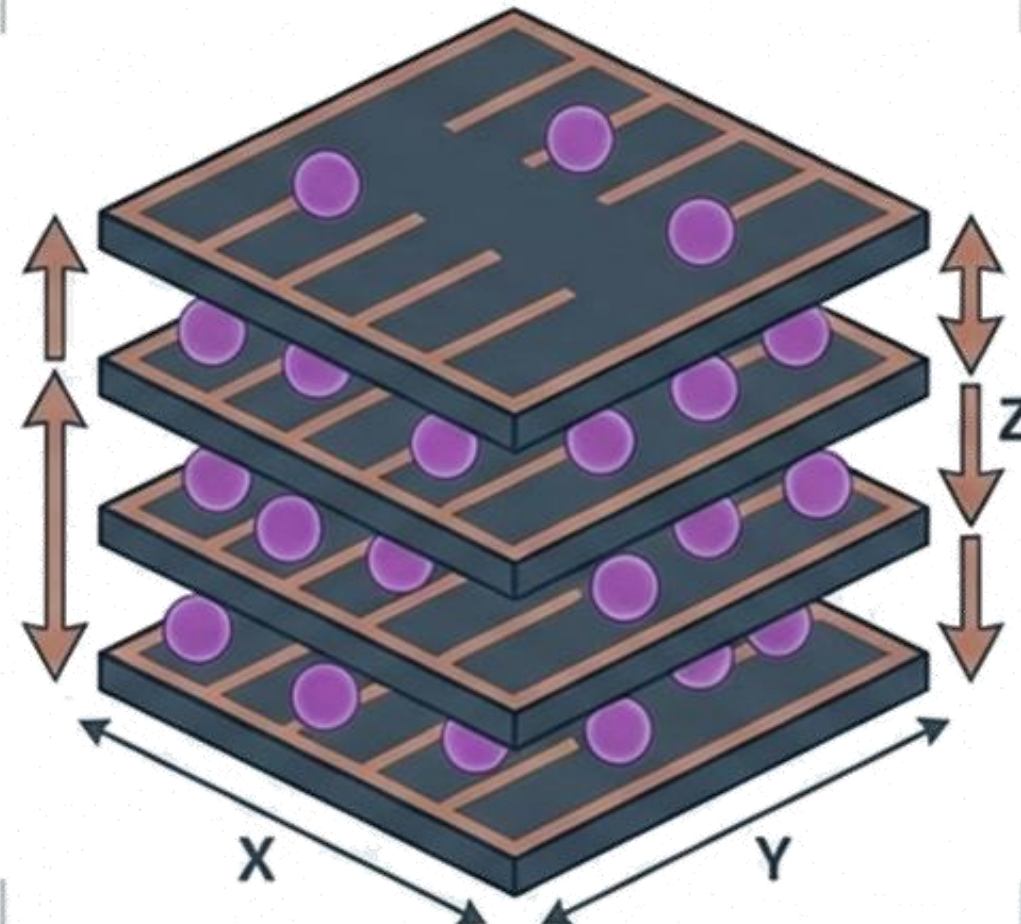

Moderate Impedance. Planar movement.

3D Diffusion (Spinel)

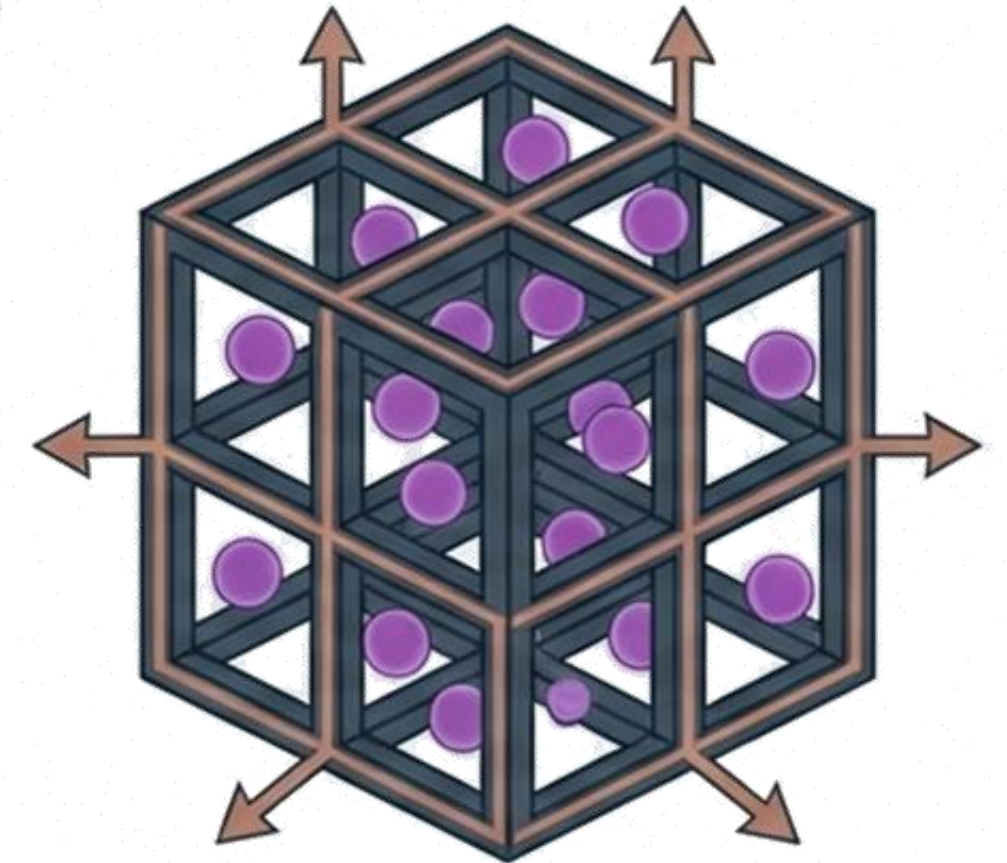

Low Impedance. Multi-directional flow.

Cathodes are strictly categorized by their crystal lattice structure, which dictates the geometric freedom of ion movement.

# Category 1: Layered Oxides (2D Structure)

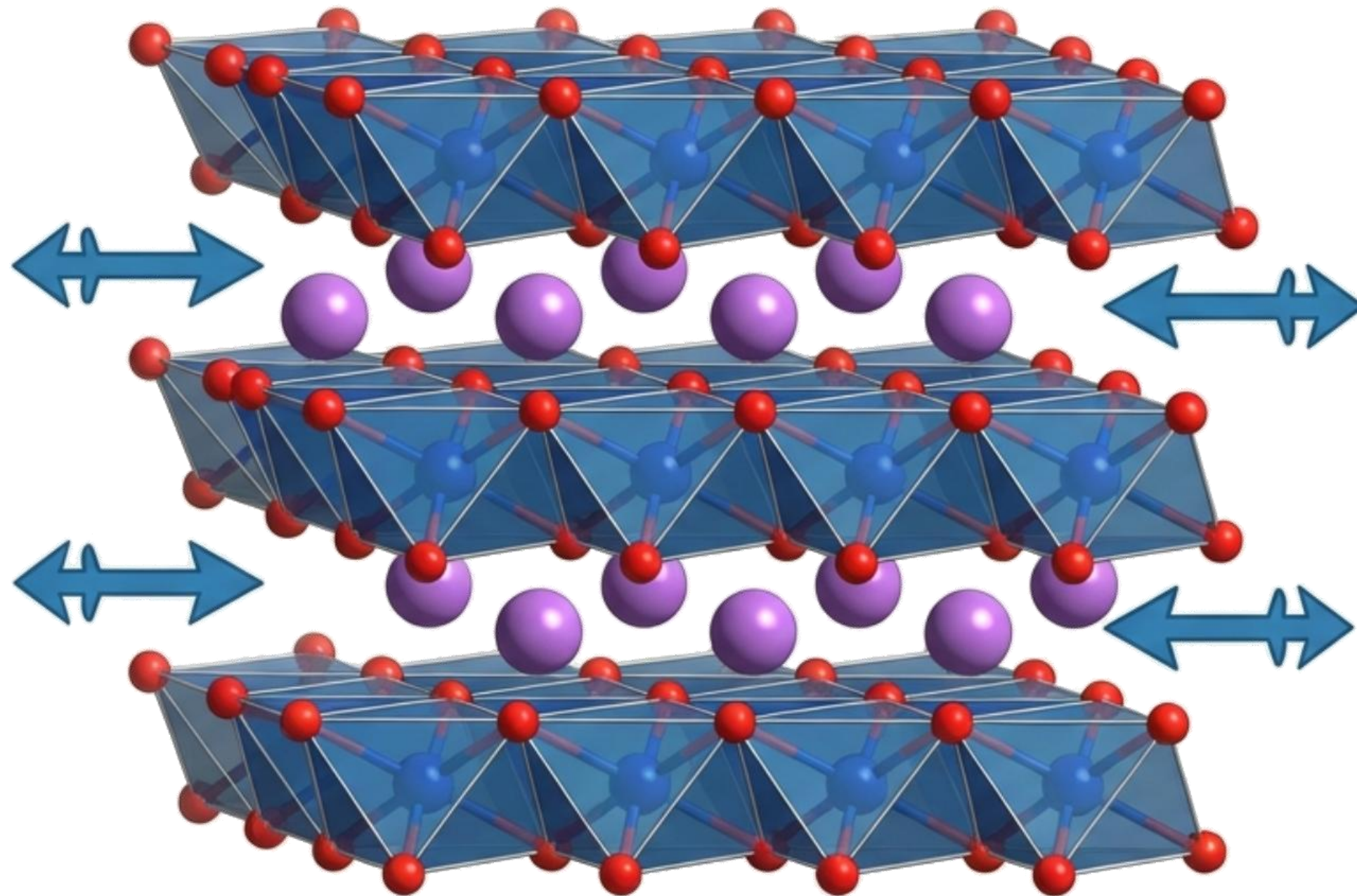

2D Ion Movement

**Formula:**  $\text{LiCoO}_2$

**Dimensionality:** 2D Layered

**Physics:**

- $\text{Li}^+$  moves between  $\text{CoO}_2$  slabs.

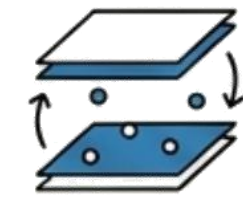

**Constraint:**

- Stability Limit ( $x \approx 0.5$ ).  
Extracting >50% of Lithium causes layers to collapse.



**Issues:**

- Cobalt is toxic, expensive, and thermally unstable.



**Characteristics:**

- High packing density (Energy).
- Standard for portable electronics.

# Lithium-ion cell makeup: Positive electrodes

Notes

- ❑ There is much more variability in the choice for positive electrodes.
- ❑ In 1980, John B. Goodenough discovered that  $\text{Li}_x\text{CoO}_2$  (LCO) (lithium cobalt oxide) was a viable material for lithium intercalation.
- ❑ LCO has layers, somewhat like graphite, so it is often called a “layered cathode”.
- ❑ This LCO material is commonly used in portable electronics cells, but suffers some problems when trying to scale up:
  - ✓ Cobalt is rare, toxic, and expensive;
  - ✓ Only about half the theoretic capacity is useable, else the cell ages rapidly.

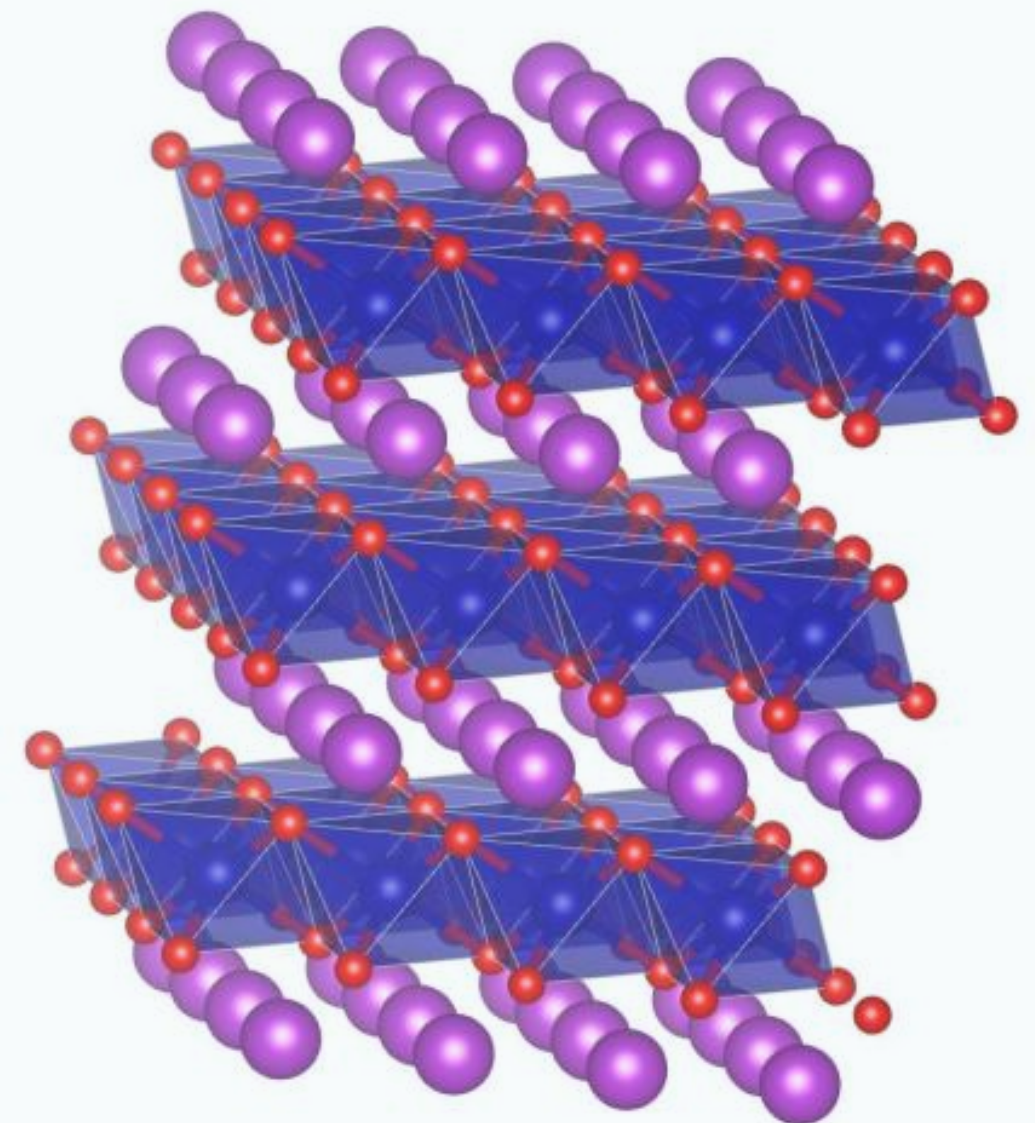

# Optimizing the 2D Structure: NCM & NCA

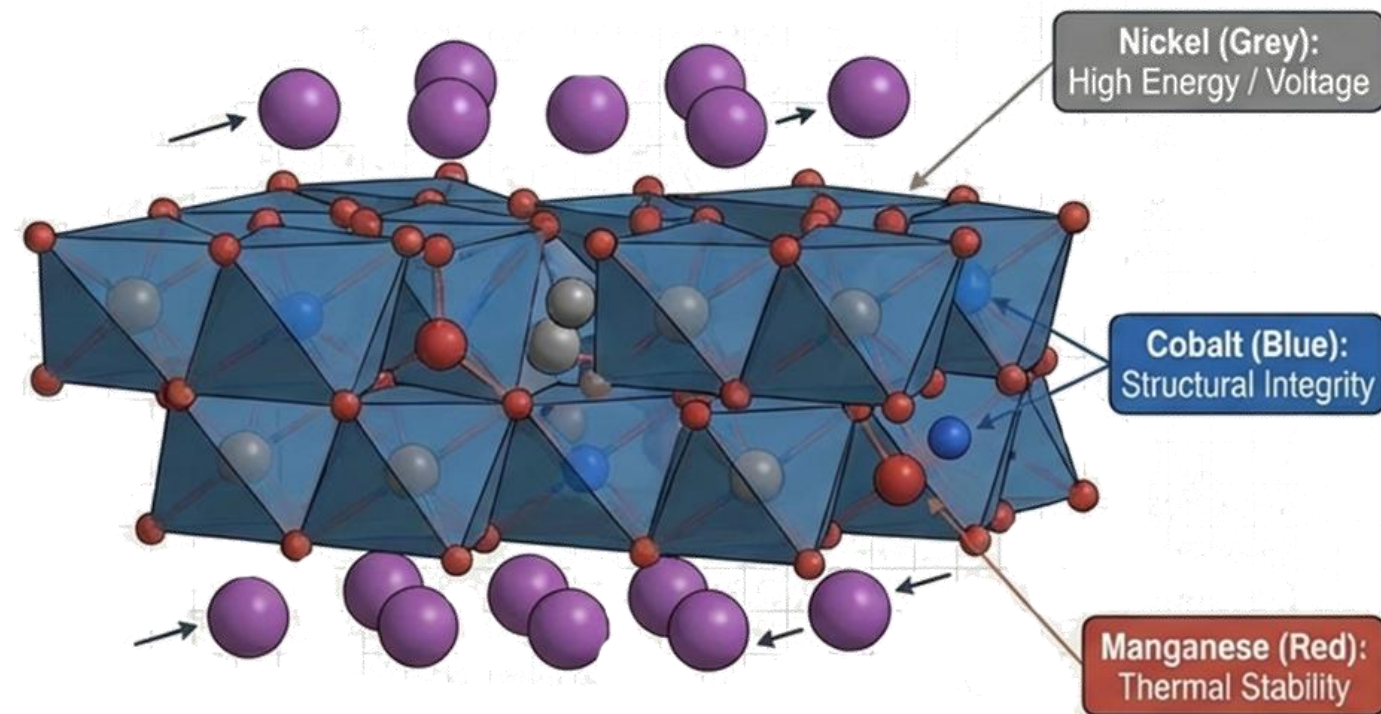

## Engineering Goal:

Retain the 2D Layered topology but replace expensive/toxic Cobalt.

## NCM (Nickel-Cobalt-Manganese):

A balanced alloy. Adjusting the ratio (e.g., 8:1:1 vs 5:2:3) tunes the Energy vs. Stability trade-off.

## NCA (Nickel-Cobalt-Aluminum):

Replaces Manganese with Aluminum for stability.

Result: Same 2D diffusion physics, optimized material properties.

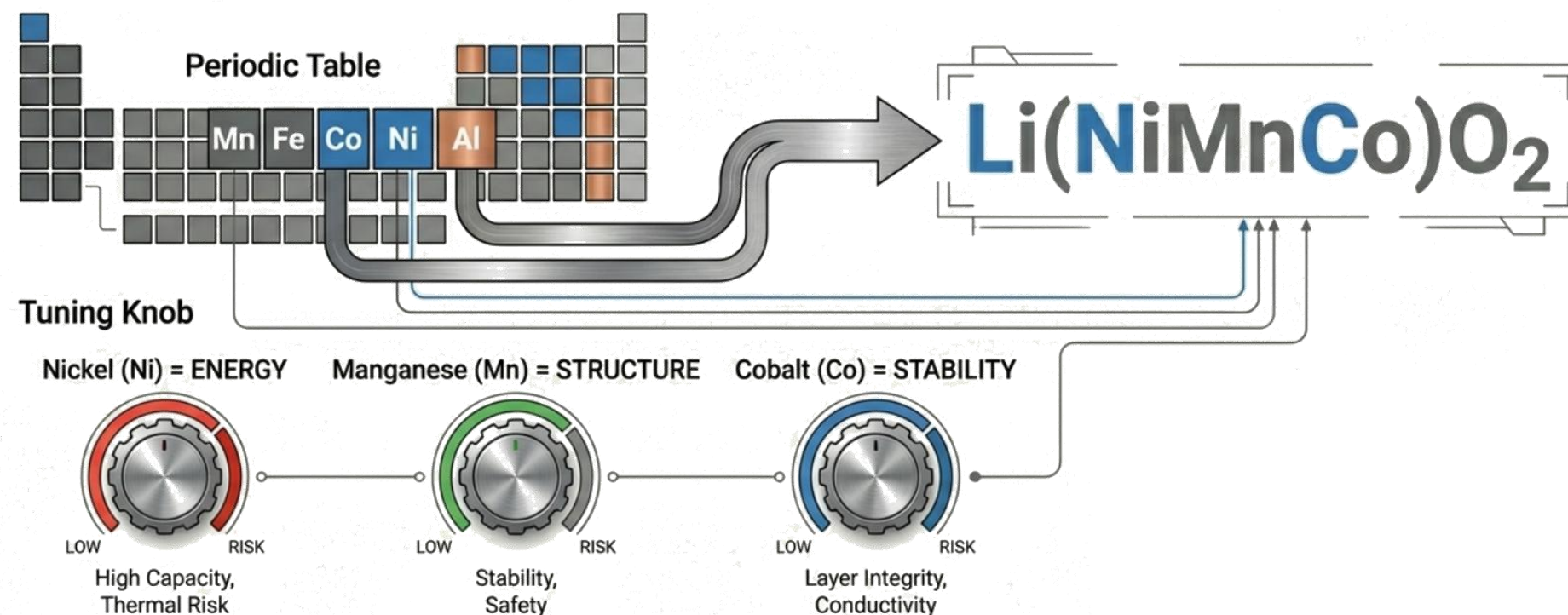

# Lithium-ion cell makeup: Positive electrodes

Notes

- ❑ **Nickel** can be substituted for cobalt, resulting in higher energy density (higher voltages at same capacity), but is not very thermally stable. **Aluminum**, **chromium**, and **manganese** can be substituted as well, resulting in somewhat different properties.
- ❑ **NCM** (a.k.a. NMC) is a blend of **nickel**, **cobalt**, and **manganese**, which retains the **layered structure**, and has properties from all three constituent metals.
- ❑ **NCA** is a blend of **nickel**, **cobalt**, and **aluminum**, which has also been commercialized (Saft).

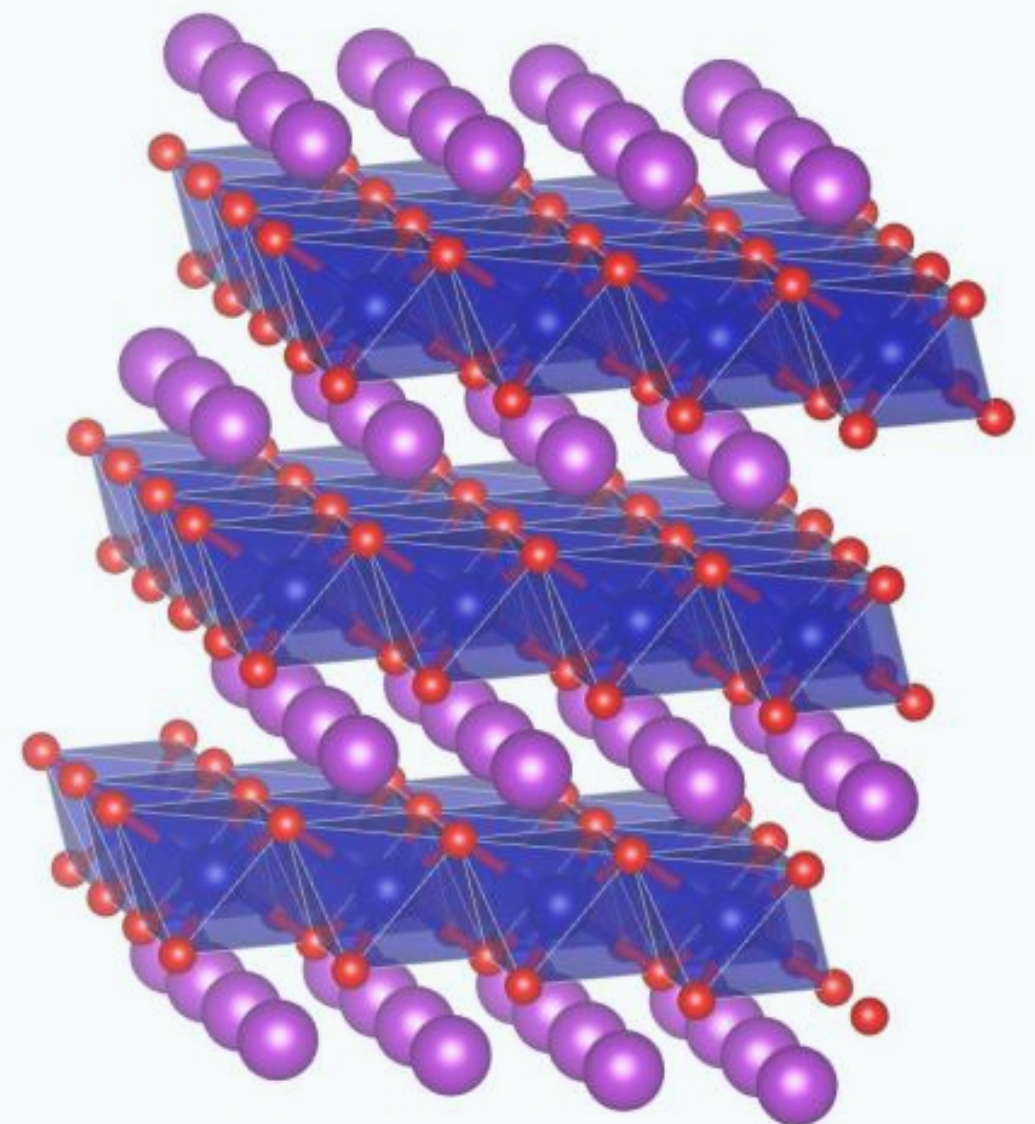

## Category 2: SPINEL (3D Structure)

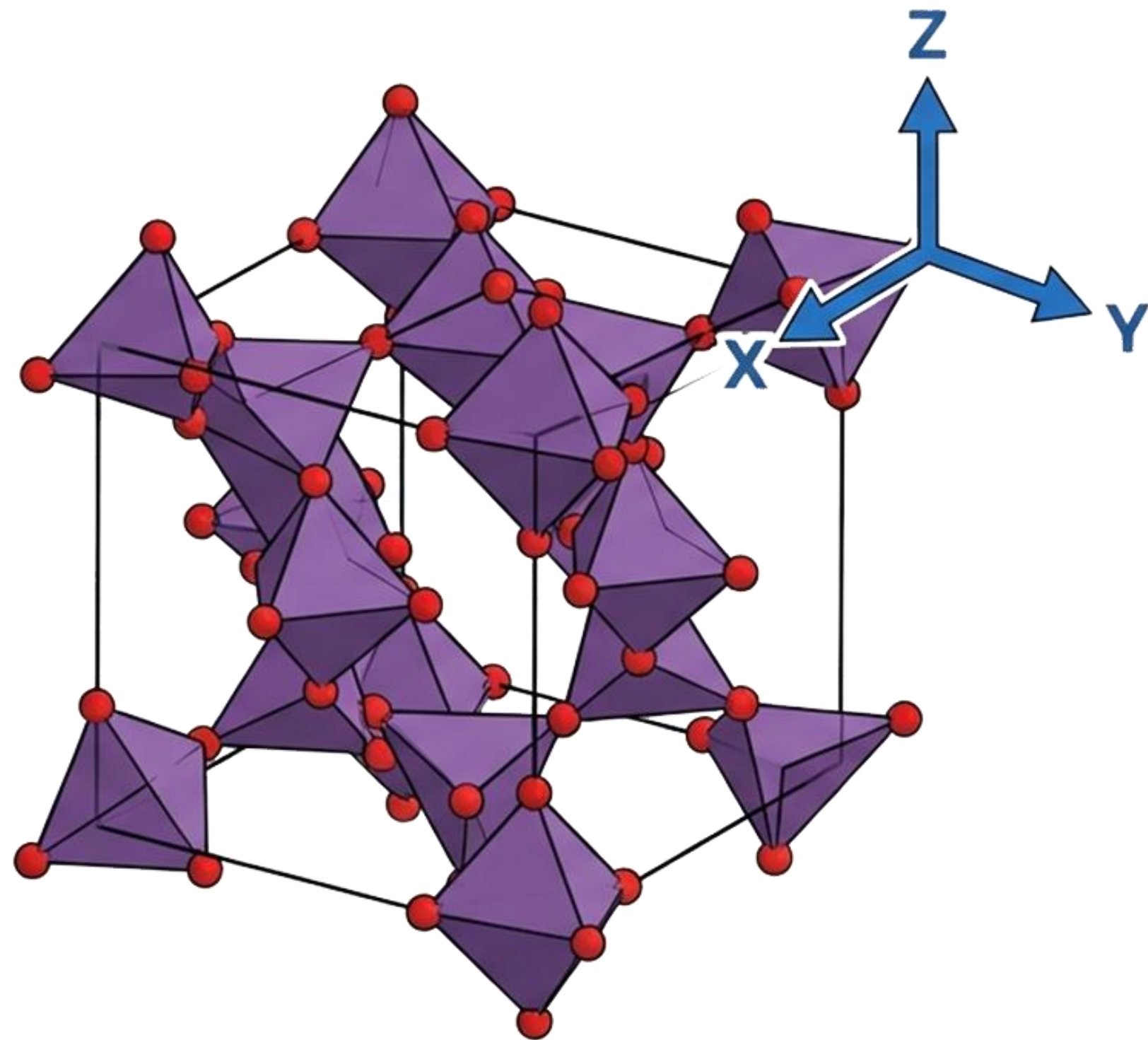

**Primary Material:** Lithium Manganese Oxide ( $LiMn_2O_4$  / LMO)

**Topology:** Cubic Spinel Lattice. Mn in octahedral sites; Li in tetrahedral sites.

**Physics:** 3D Diffusion. Ions move freely in X, Y, and Z directions.

**Implication:** Low internal resistance = High Power Capability.

**Failure Mode:** Manganese dissolution into electrolyte at high temperatures reduces cycle life.

# Lithium-ion cell makeup: Positive electrodes

Notes

- ❑ In 1983, Goodenough and Thackeray proposed  $\text{Li}_x\text{Mn}_2\text{O}_4$  (**LMO**) as an alternate intercalation material: Mn sits in the octahedral sites, Li in the tetrahedral.
- ❑ This material has a **cubic “spinel”** structure. It allows 3D diffusion (vs. 2D for layered and 1D for olivine).
- ❑ The value of “x” typically varies between 0 and 1, but can go as high as 2 (LMO is unstable in acidic conditions when “x” is greater than 1).
- ❑ The **LMO** positive-electrode material is cheaper and safer than **LCO**, but can have short lifetime due to the manganese dissolving into the electrolyte under some conditions.

## $\text{Li}_x\text{Mn}_2\text{O}_4$ (LMO)

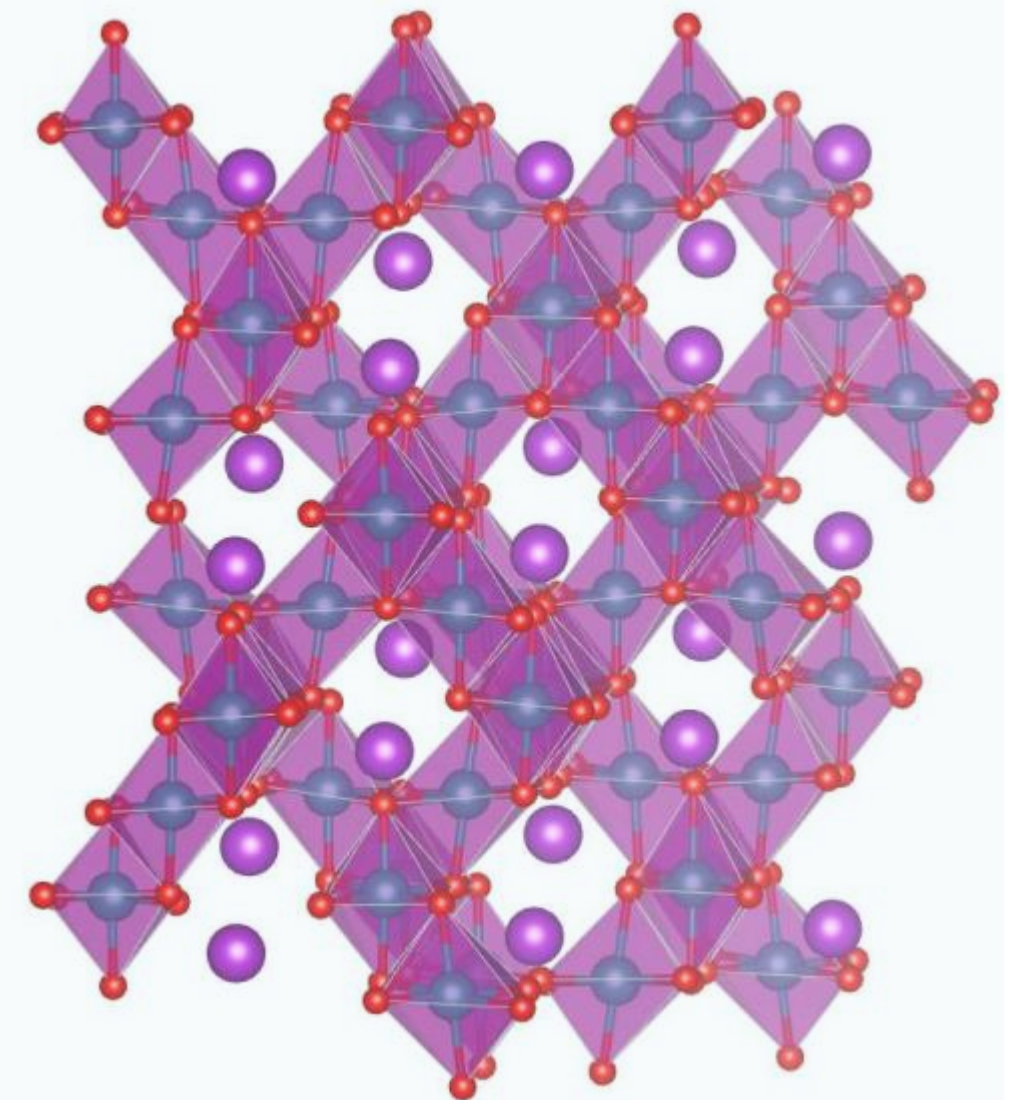

# Category 3: OLIVINE (1D Structure)

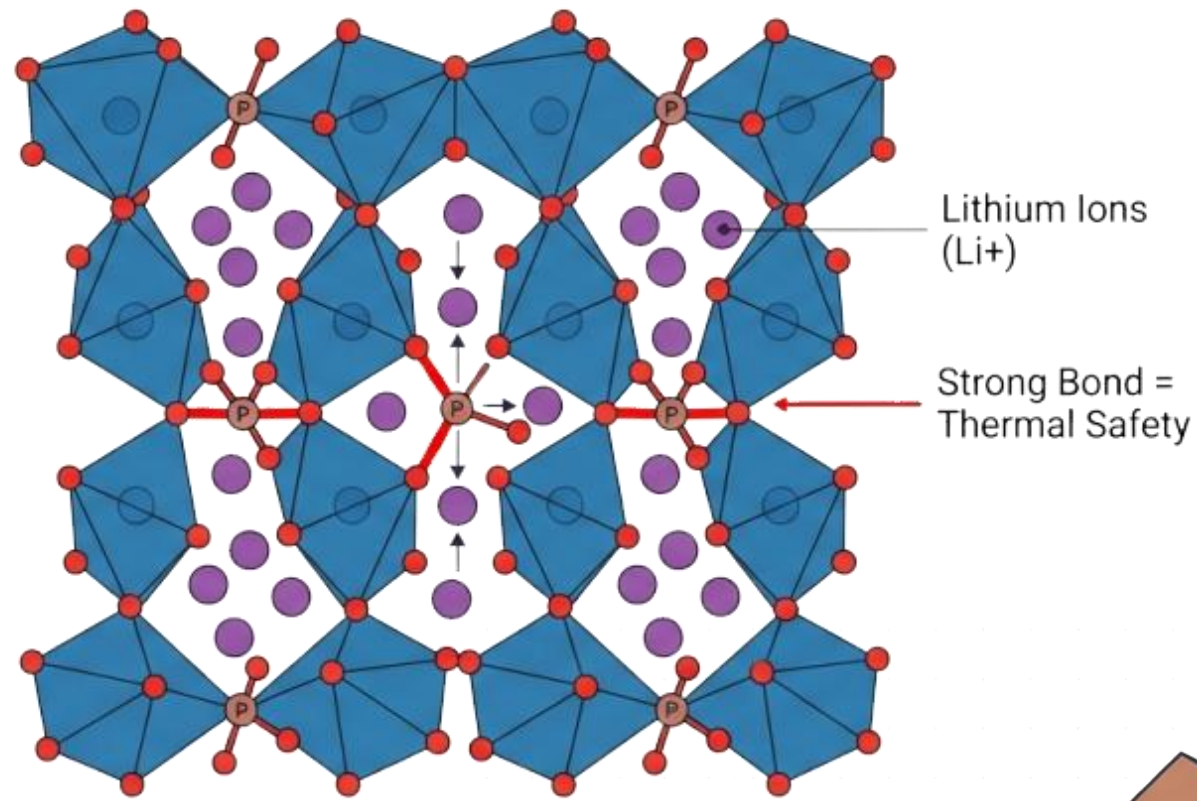

1D Straight Tunnel Diffusion

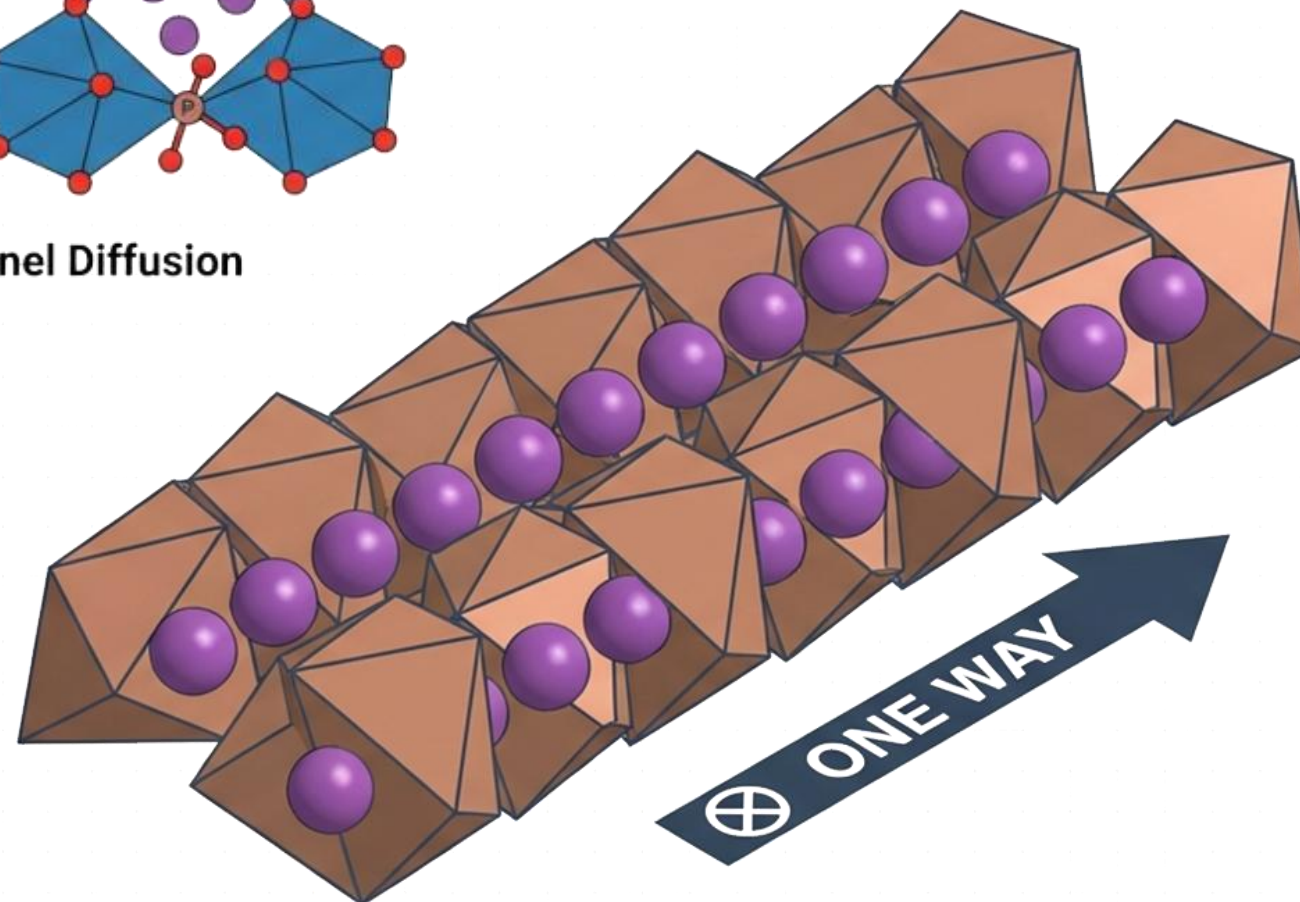

**Primary Material:** Lithium Iron Phosphate (LiFePO<sub>4</sub> / LFP)

**Topology:** Olivine-style phosphate lattice.

**Physics:** 1D Diffusion. Ions restricted to specific linear tunnels.

**Implication:** Higher Impedance (Resistance). Susceptible to 'ionic traffic jams' if the channel is blocked.

**Trade-off:**

- Pros: Extremely stable (Safe), Abundant materials (Cheap).
- **Cons:** Lower voltage and energy density.

# Lithium-ion cell makeup: Positive electrodes

Notes

- ❑ In 1997, Goodenough proposed olivine style phosphates as a third major category of positive-electrode material.
- ❑  $\text{Li}_x\text{FePO}_4$  (LFP) is the most common in this family.
- ❑ This material is **low cost**, and **low toxicity**, but also **low energy density**.
- ❑ 1D structure tends to have high resistance.
- ❑ There are other candidate materials, mostly mixtures of the above.

LFP

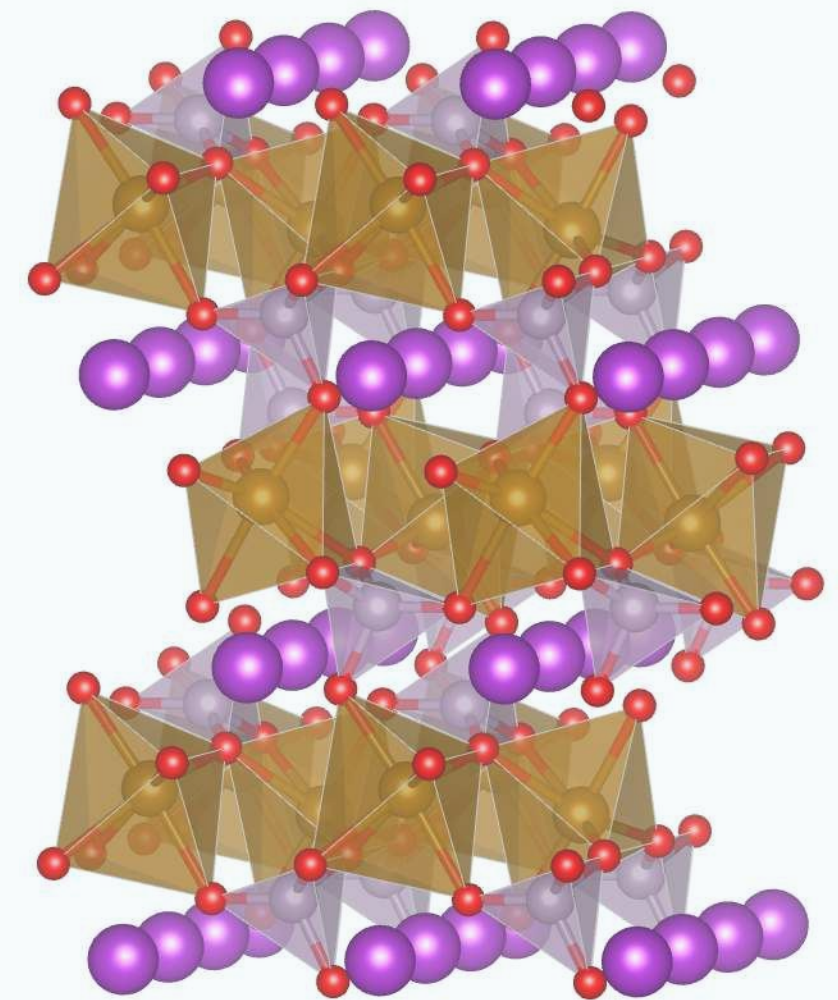

# Positive Electrode Reference Matrix

Material	Structure (Dim)	Voltage	Key Advantage	Key Disadvantage
LCO (Cobalt)	2D Layered	3.7V - 4.2V	High Energy Density	Toxic / Expensive
NMC (Ni-Mn-Co)	2D Layered	3.6V - 4.3V	Balanced Performance	Thermal Instability (Hi-Ni)
LMO (Spinel)	3D Cubic	3.8V	High Power / Low Cost	Capacity Fade (Mn Dissolution)
LFP (Phosphate)	1D Olivine	3.2V	Max Safety / Cycle Life	Low Energy / Low Voltage

# The Electrolyte: The ION Highway

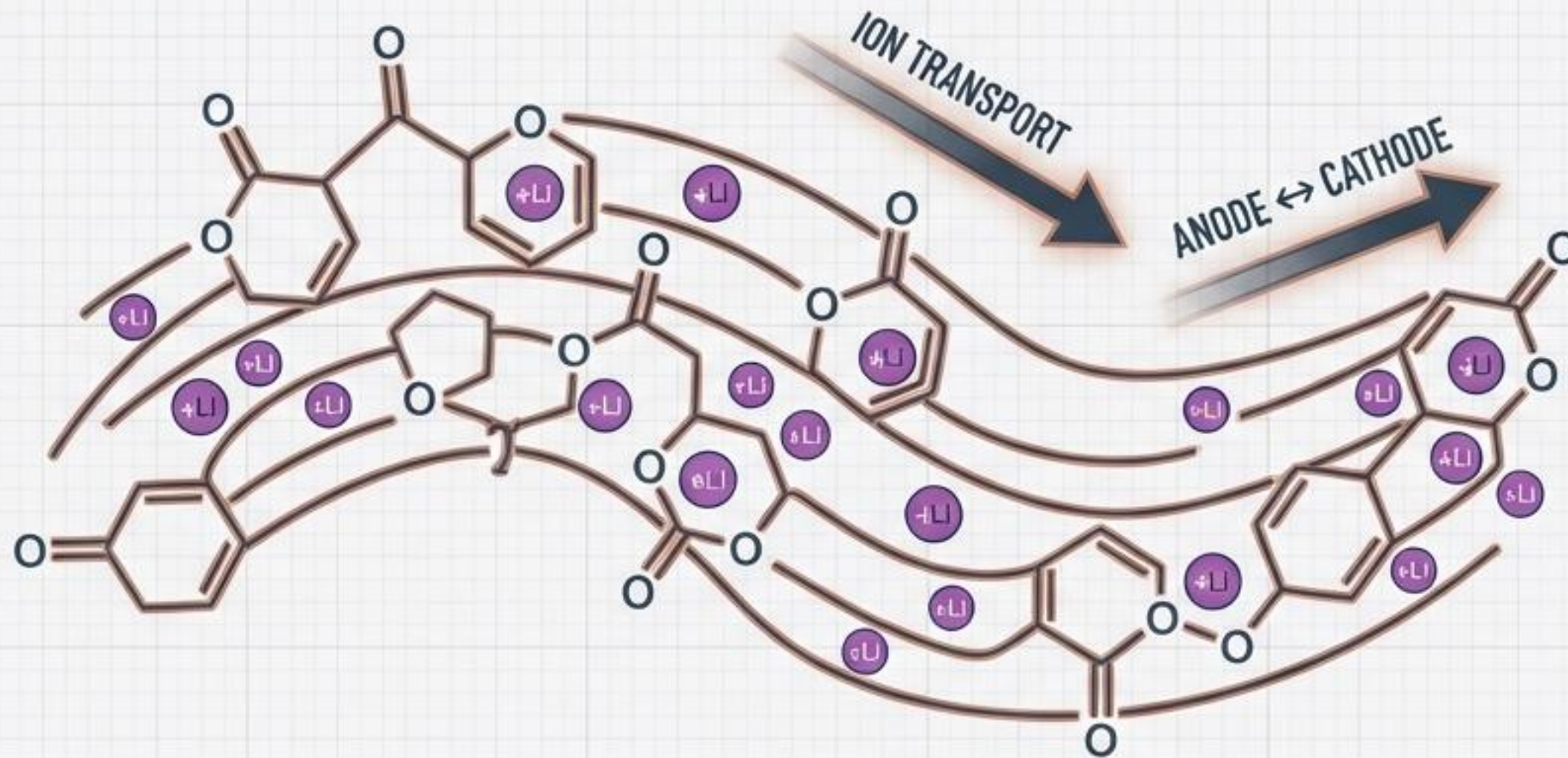

**Function:** The conductive medium connecting the electrodes. Must be electronically insulating but ionically conductive.

## Composition:

1. **Salt:** Lithium Hexafluorophosphate ( $\text{LiPF}_6$ ) is the industry standard.
2. **Solvent:** Non-aqueous organic carbonates (EC, PC, DMC).

## Critical Engineering Constraints:

- **Non-Aqueous:** Water causes immediate hydrolysis and potential thermal runaway.
- **Passivity:** Ideally participates *only* in transport, not reaction.

# Separator: The Final Line of Defense

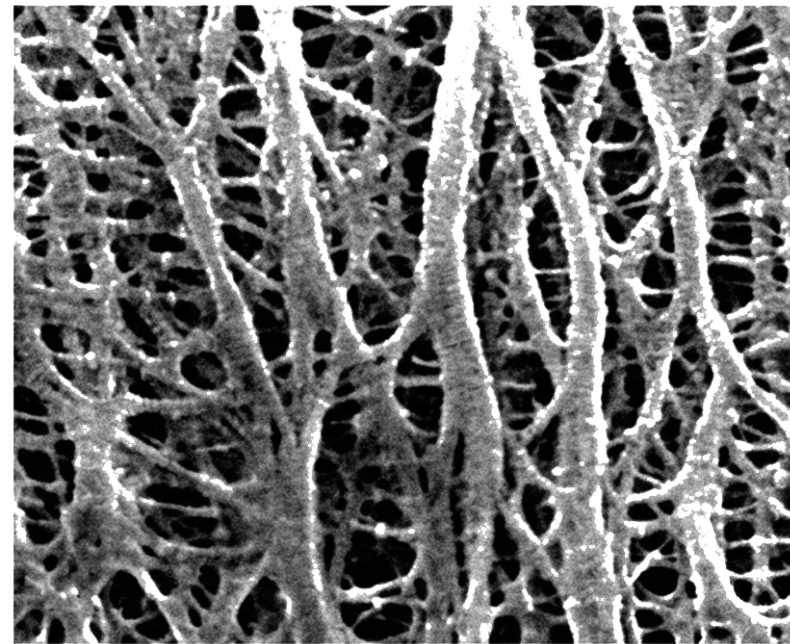
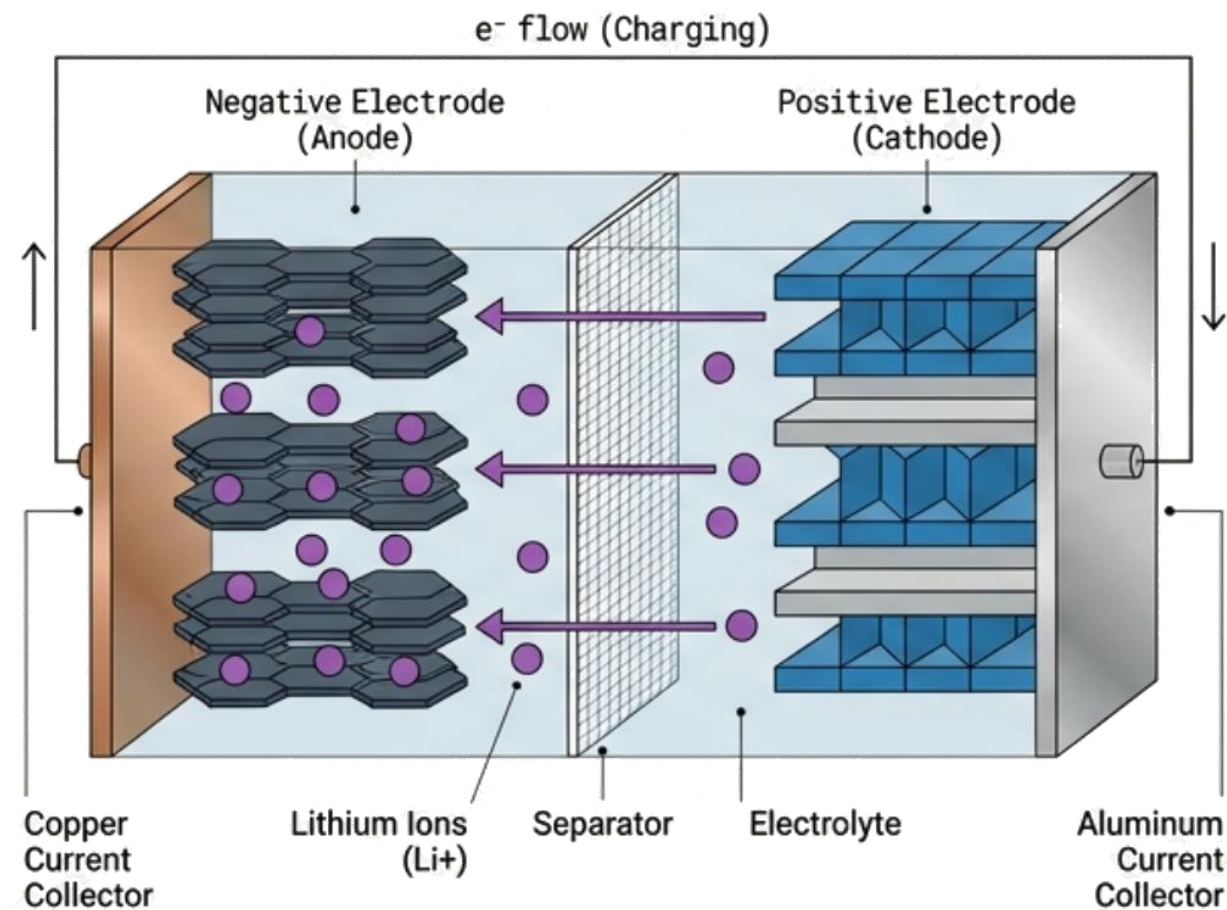

MICROSCOPIC STRUCTURE (SEM VIEW)

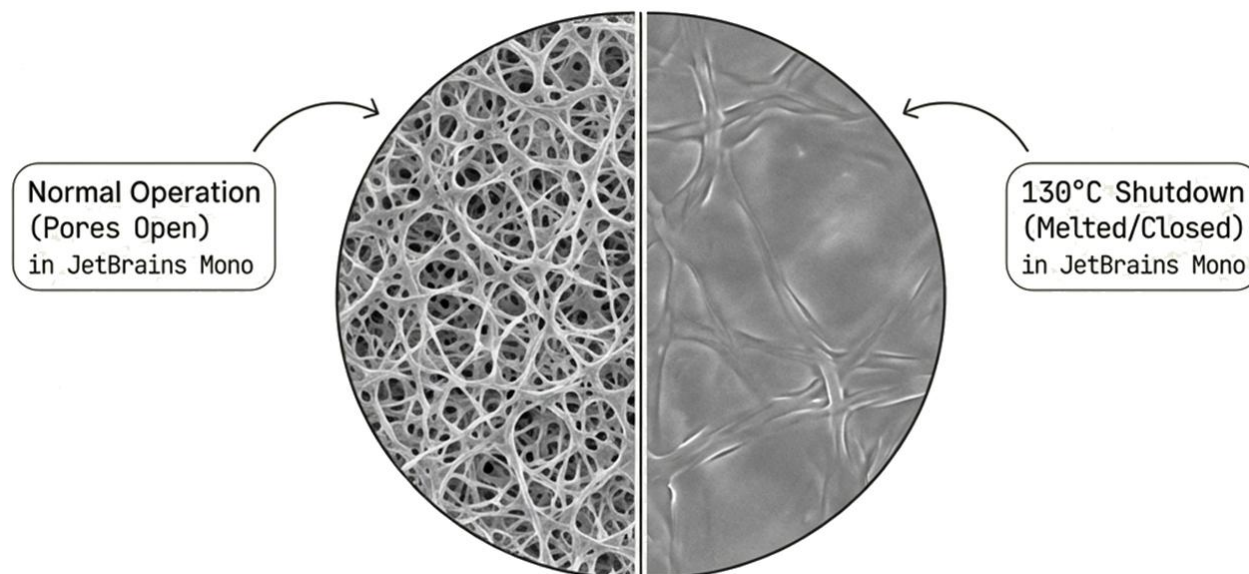

- **Physical Structure:** Porous Polyethylene (PE) or Polypropylene (PP) membrane.
- **Function 1 (Insulator):** Physically separates **Anode** and **Cathode** to prevent electronic short circuits.
- **Function 2 (Filter):** Micropores allow  $Li^+$  ions to permeate freely.
- **Safety Mechanism:** Some separators are designed to melt and close pores (shutdown) if temperature spikes, cutting off ion flow.

# Summary: The Balance of Materials

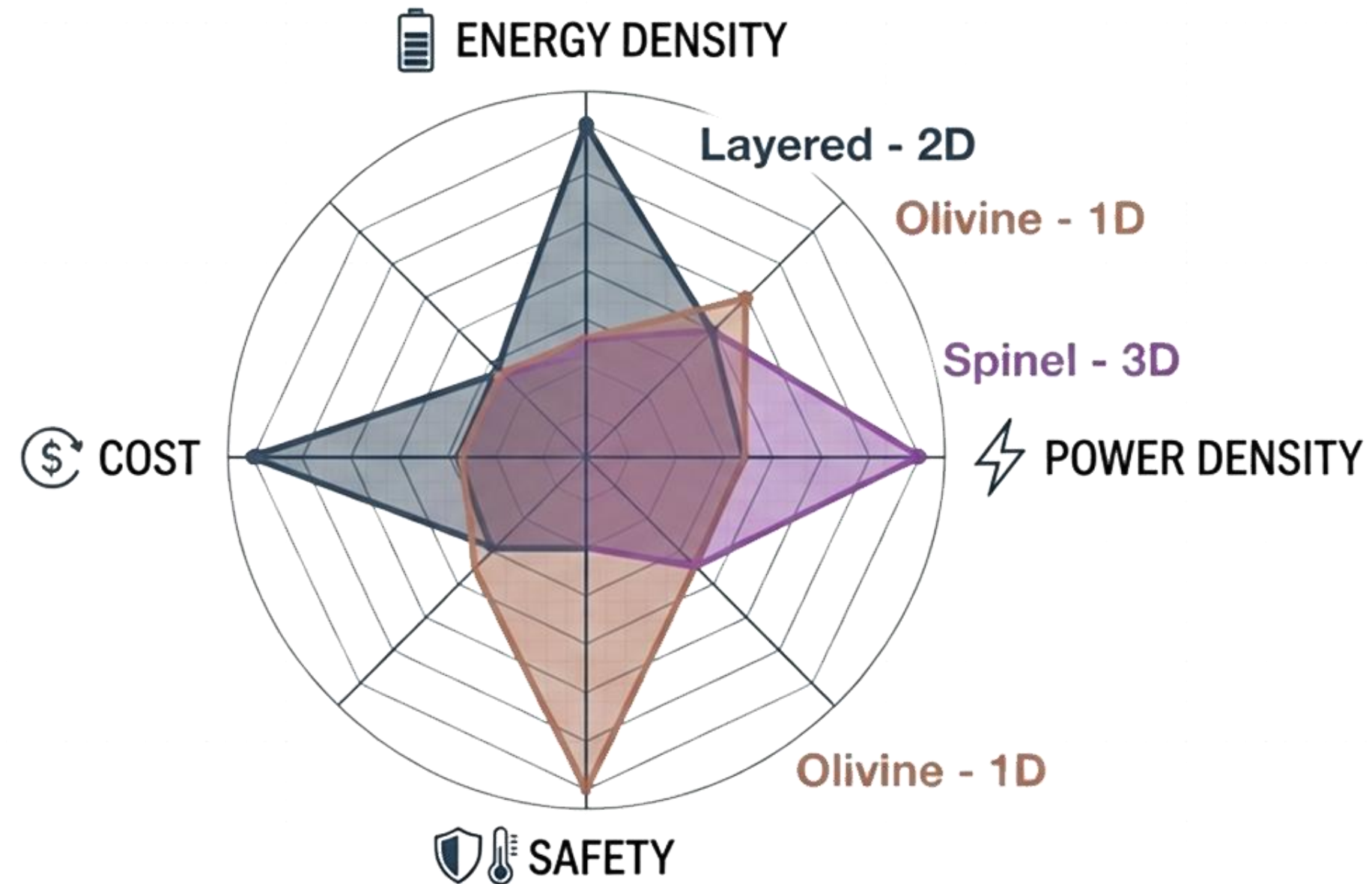

Material selection is a compromise driven by the specific requirements of the electronic load. There is no “perfect” battery chemistry.

# **Battery Fundamentals**

## **The Anatomy of Lithium-Ion Cell**

# The Lithium Myth: Abundance vs. Scarcity

The Perceived shortage of lithium is a challenge of extraction and refinement, not geological existence.

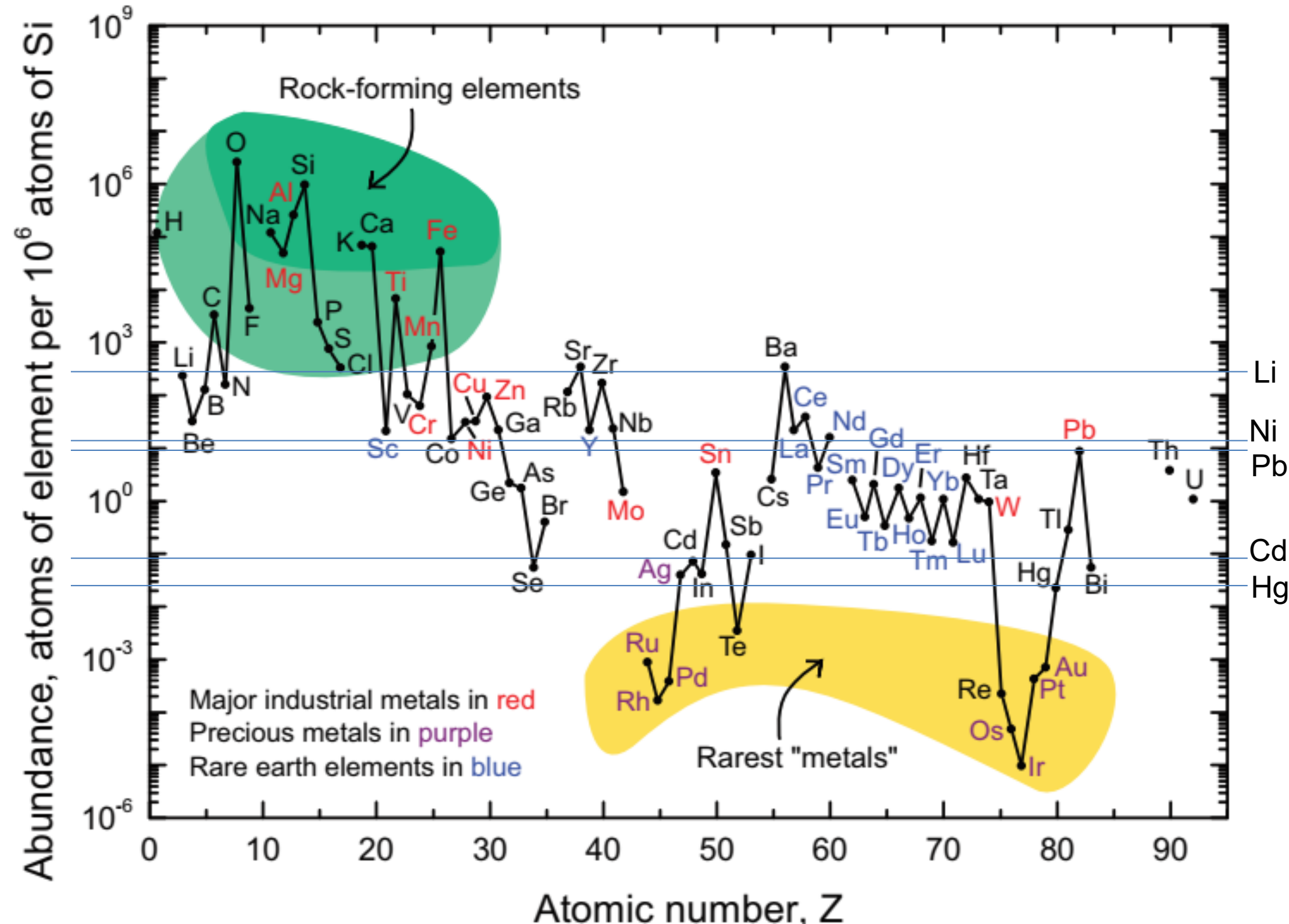

## Elemental Abundance

Lithium is 20 to 100 times more abundant in total atom count than common industrial metals like lead and nickel.

## High Reactivity

It is rarely found in a free state. Its highly reactive nature means it naturally combines with other elements, complicating extraction.

## Toxicity Comparison

Highly toxic legacy battery materials like Cadmium and Mercury are 1,000 times less common in the crust than Lithium.

# Supply vs. Automotive Demand

## The Cell & Vehicle Scale

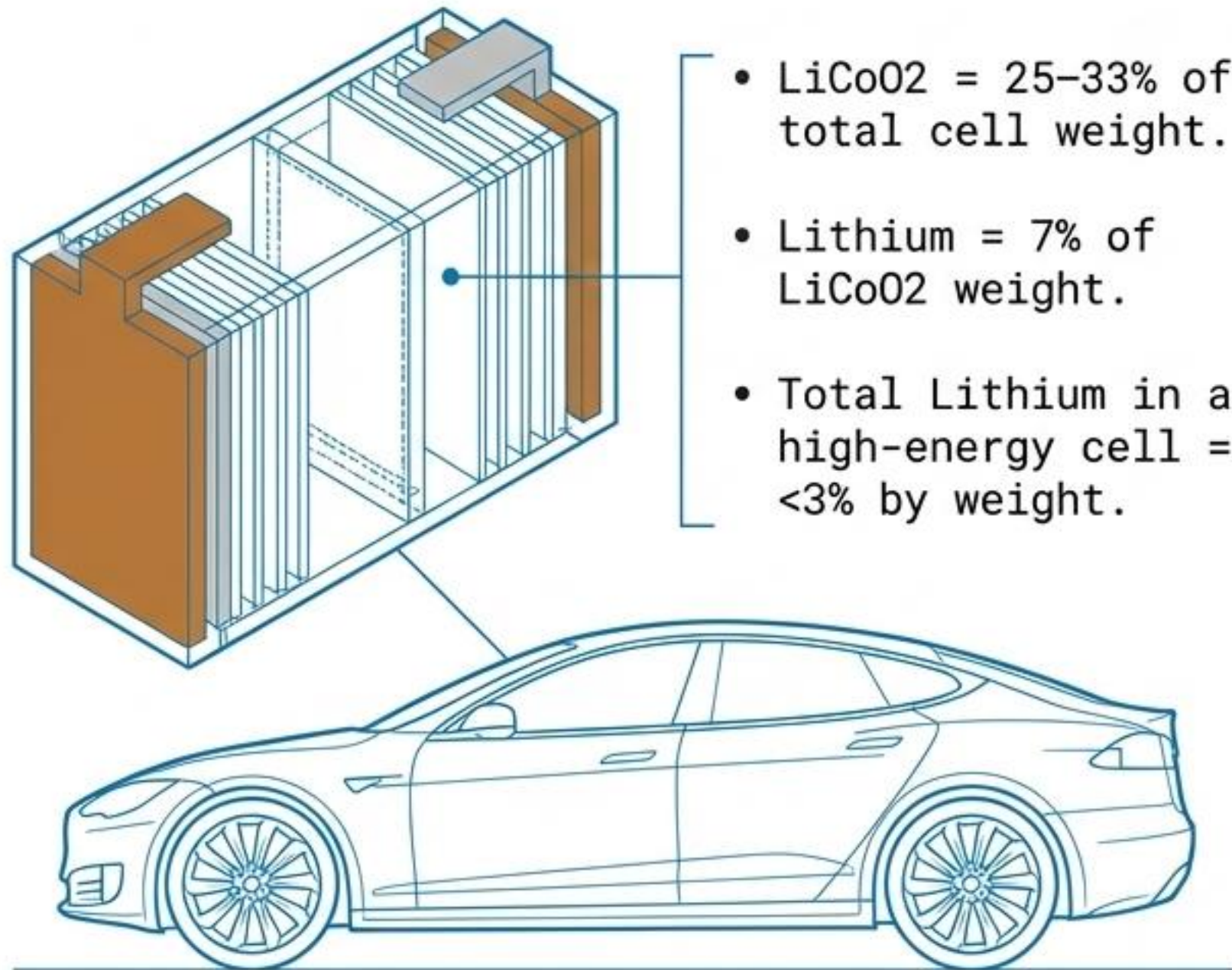

A typical 30–50 kWh EV requires only 6 to 10 kg of Lithium.

## The Global Scale

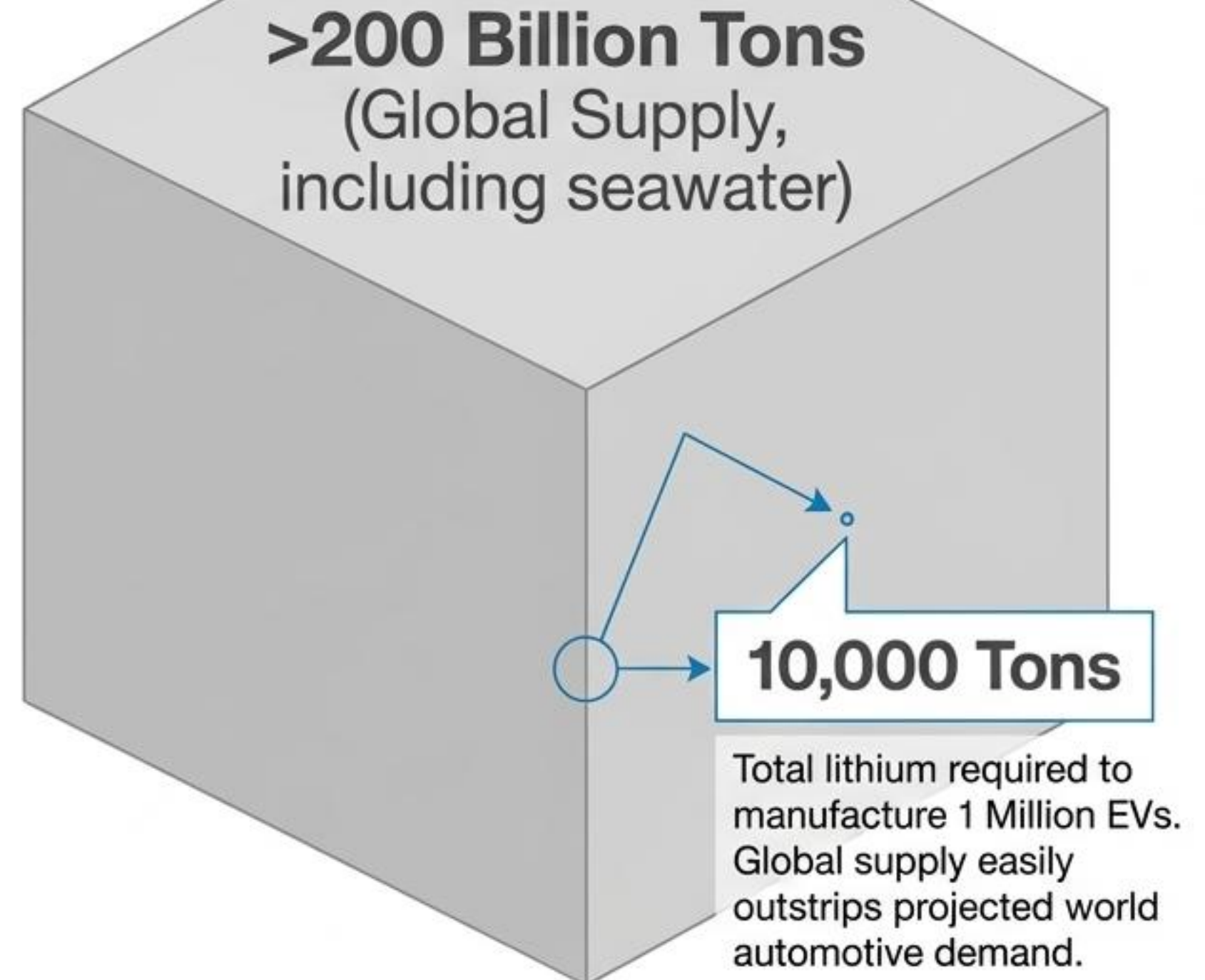

# Supply vs. Automotive Demand

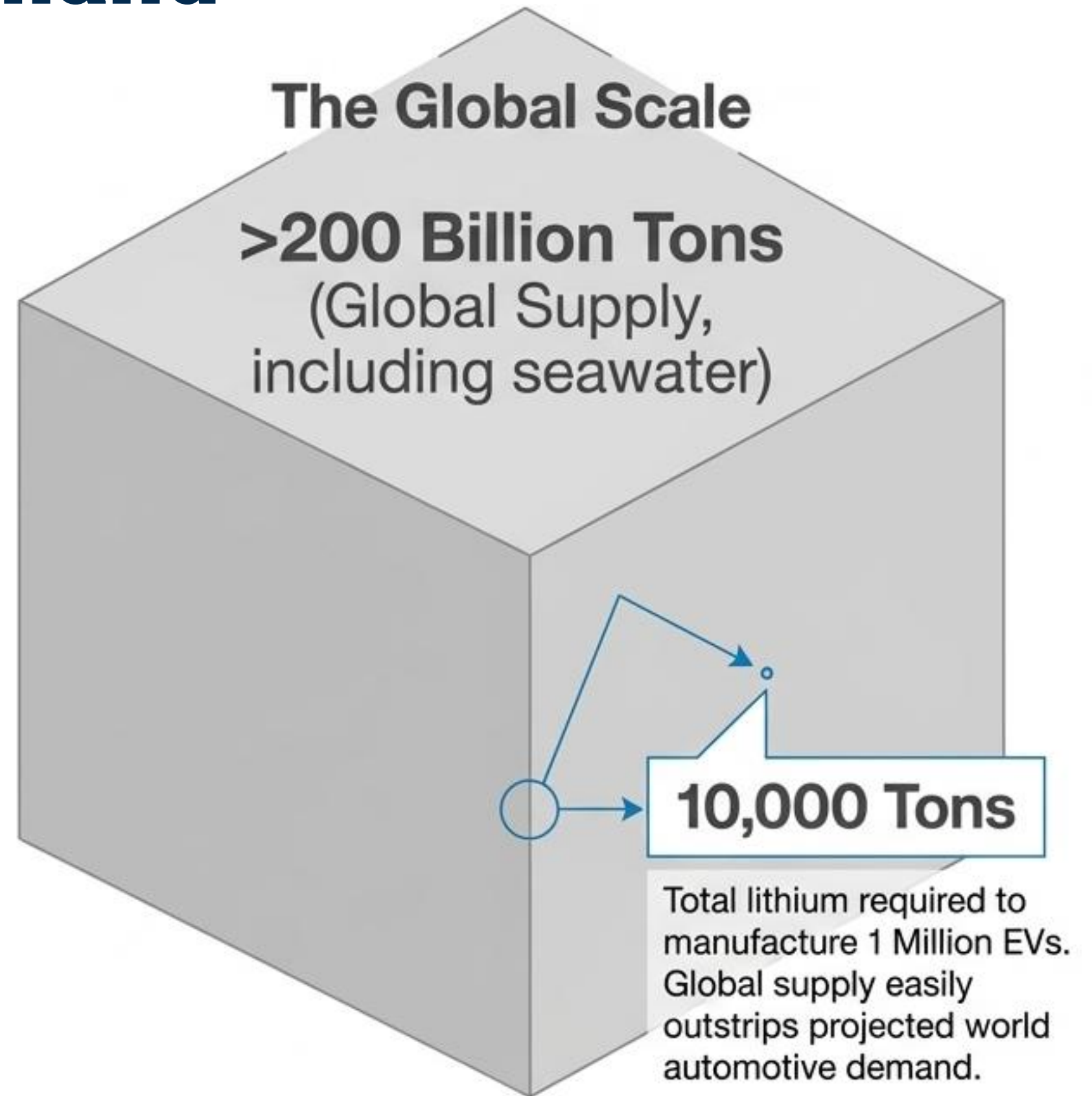
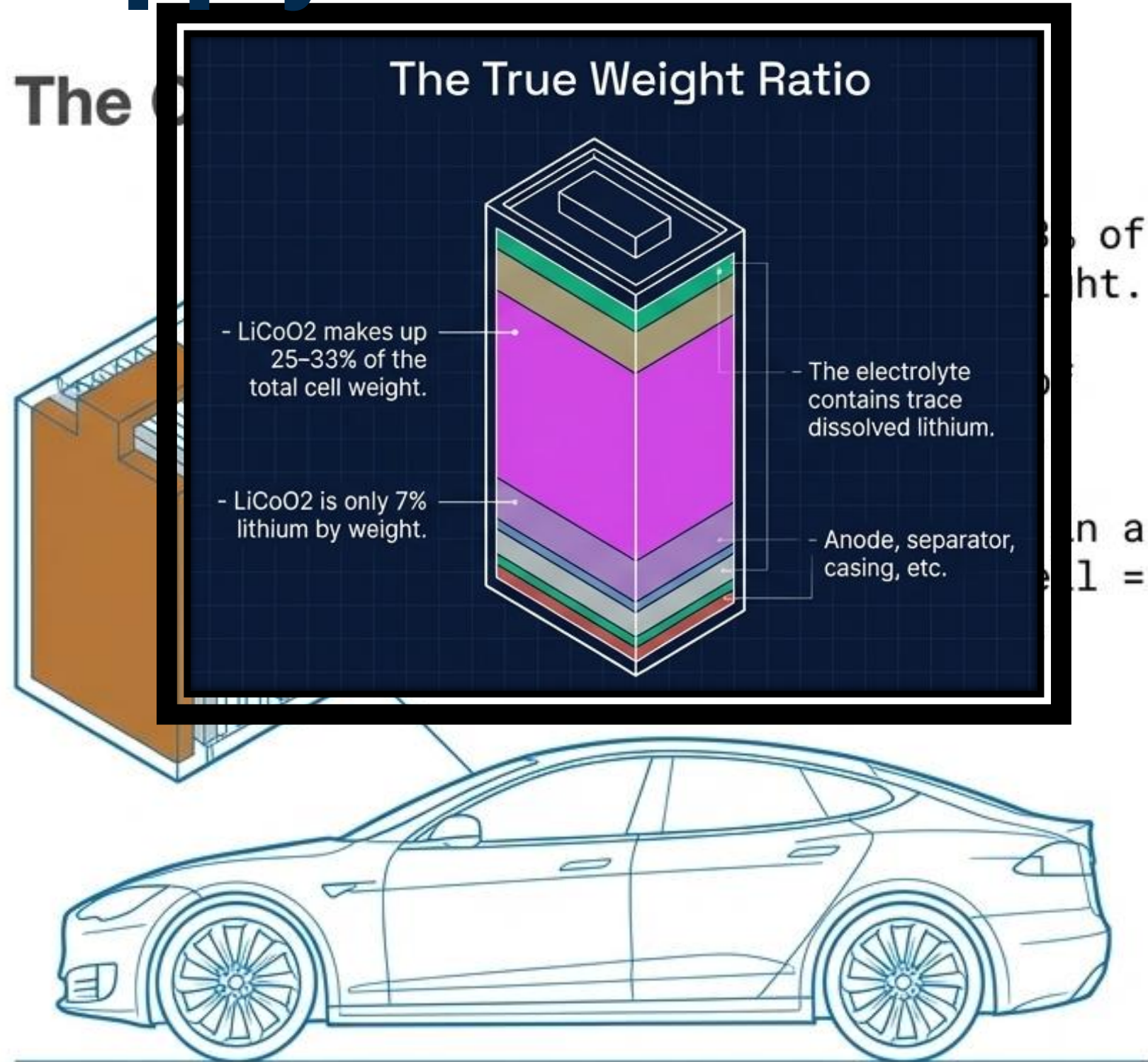

# Manufacturing Pipeline I: Coating & Drying

## Stage 1: Slurry Mixing

Active black powder mixed with conductive binders.  
Cross-contamination ruins cells; anode and cathode are processed in separate cleanrooms.

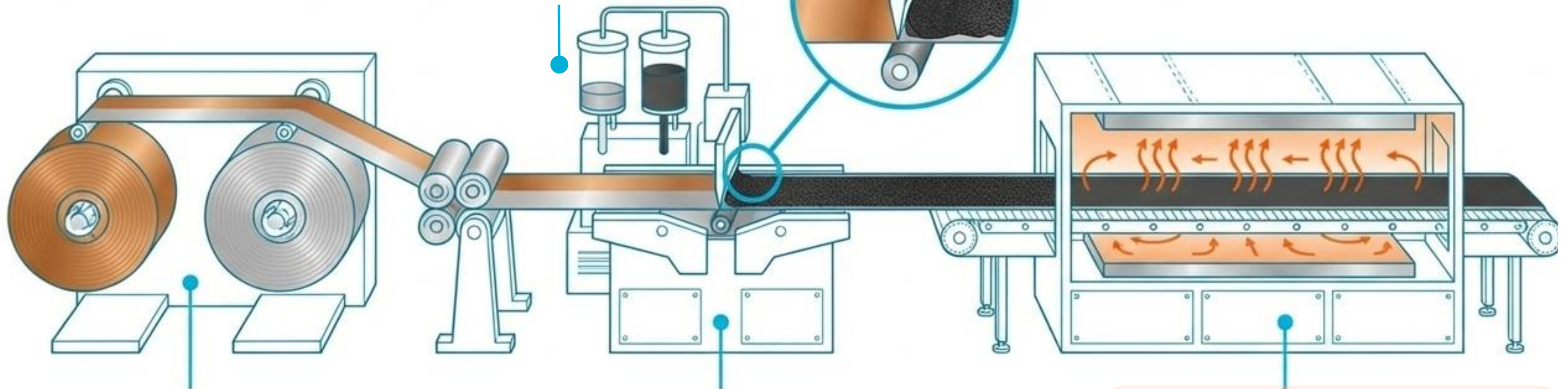
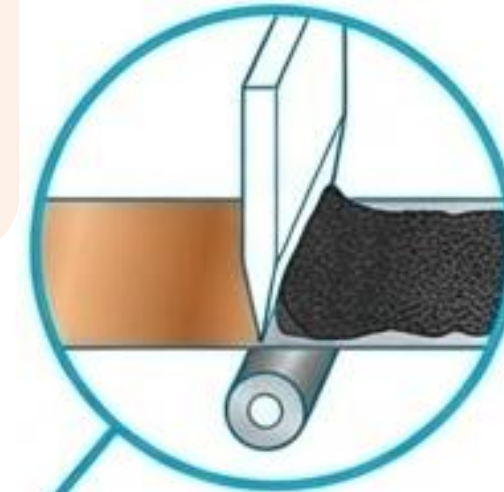

## Stage 0: The Unwinder

0.5m wide raw copper (negative) and aluminum (positive) foils feed into precision rollers.

## Stage 2: The Coater

A conductive binder + active material slurry is applied. A hyper-precise 'knife-edge' gap controls thickness. Coating thickness is perfectly calibrated to match the energy storage per unit area of positive and negative sides.

## Stage 3: The Drying Oven

The wet coated foil feeds directly into a long oven to bake the active material onto the metal before re-reeling.

# Manufacturing Pipeline II: Calendaring & Slitting

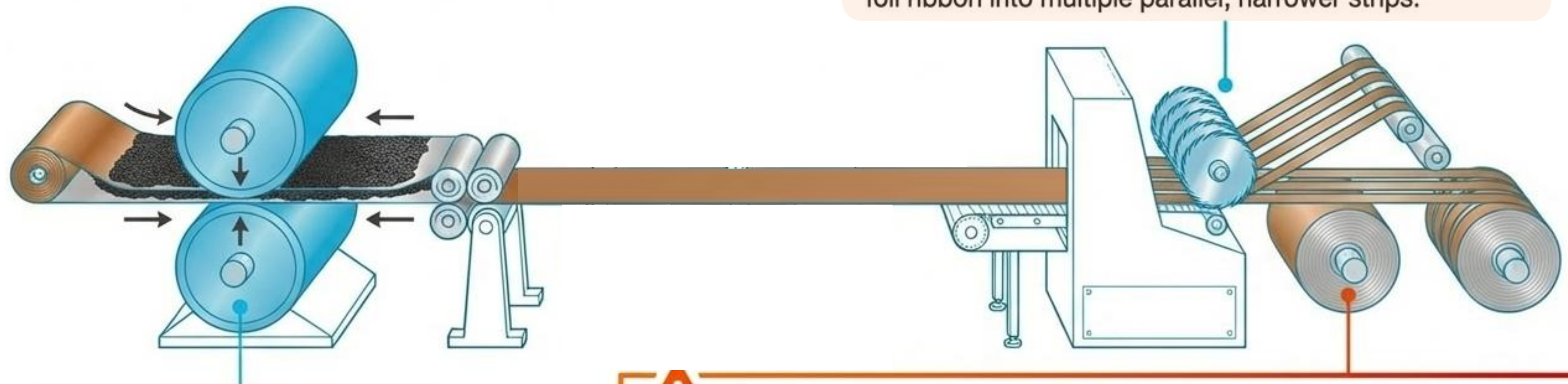

## Stage 5: The Slitter

A series of high-precision circular blades cutting the wide foil ribbon into multiple parallel, narrower strips.

## Stage 4: Roll Press (Calendaring)

Giant rollers compress the active material, pressing out porosity and physically compacting the spaces between microscopic particles for maximum density.



## CRITICAL DEFECT RISK: THE BURR

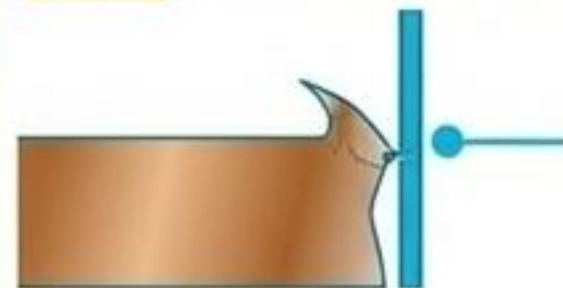

Slitting machines must be maintained perfectly. Any microscopic metal burrs left on the cut edges of the foil strips can pierce the separator during final assembly, causing an unpreventable internal short circuit.

# Manufacturing Phase 1: The Roll-to-Roll Process

Notes

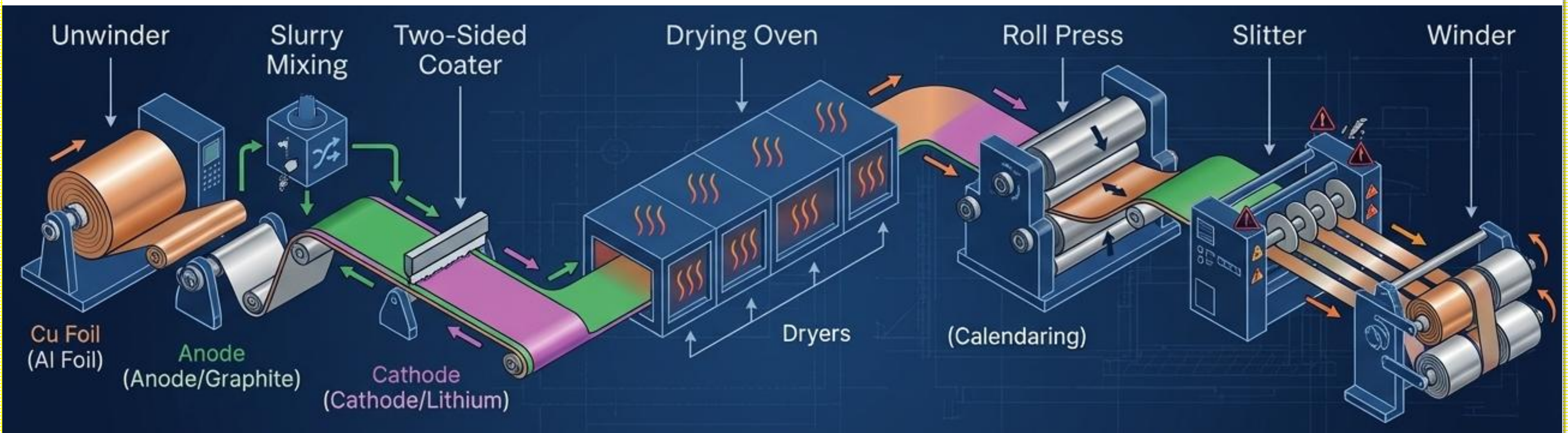

## 1. Slurry Mixing

Active black powder mixed with conductive binders.

Cross-contamination ruins cells; anode and cathode are processed in separate cleanrooms.

## 2. Coating

Reels of Copper or Aluminum foil are unreeled.

A precision knife edge applies the slurry onto the foil at exact thicknesses.

## 3. Drying

The coated foil passes through a long multi-stage oven to bake the active material onto the current collector.

## 4. Calendaring (Pressing)

Heavy steel rollers compress the active material, compacting spaces between particles and completely pressing out porosity.

## 5. Slitting

The wide foil is cut into narrow strips.

**Crucial Quality Control:** Any burrs left on the edges here can pierce the separator later, causing fatal internal short circuits.

# Cell Form Factors

The Physical architecture dictates internal geometry and application.

## Cylindrical Cells

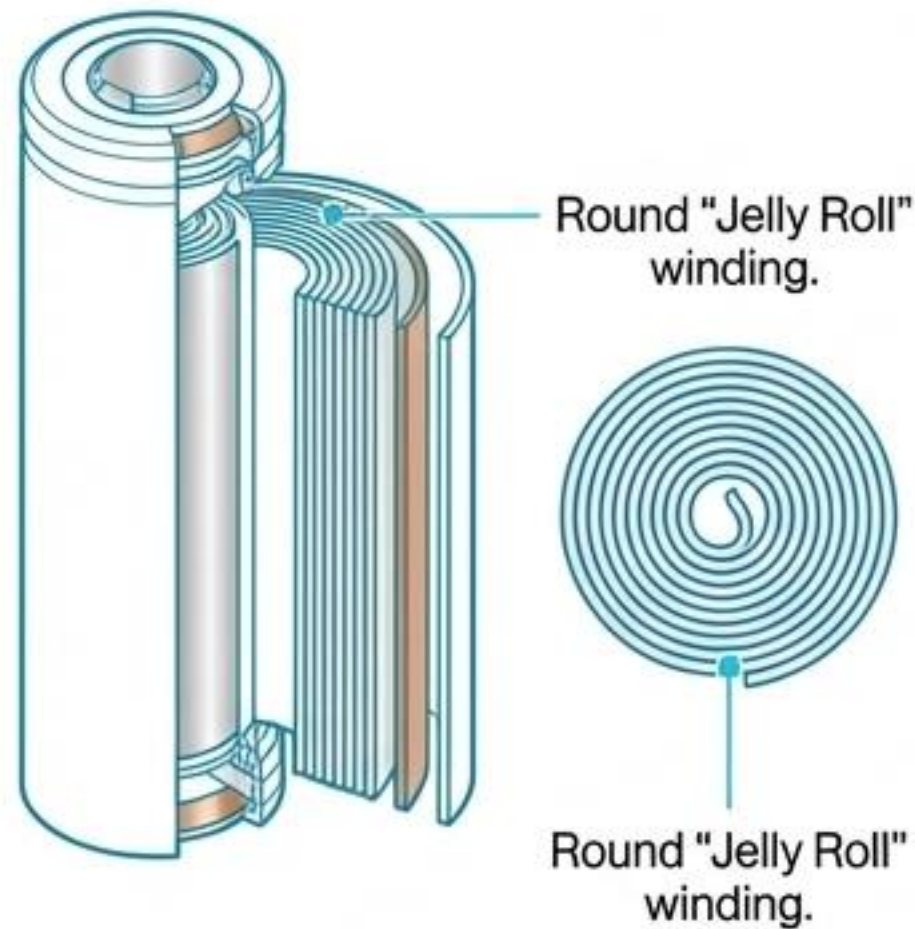

### Characteristics

- Standardized dimensions, robust mechanical integrity, excellent pressure containment.

## Prismatic Cells

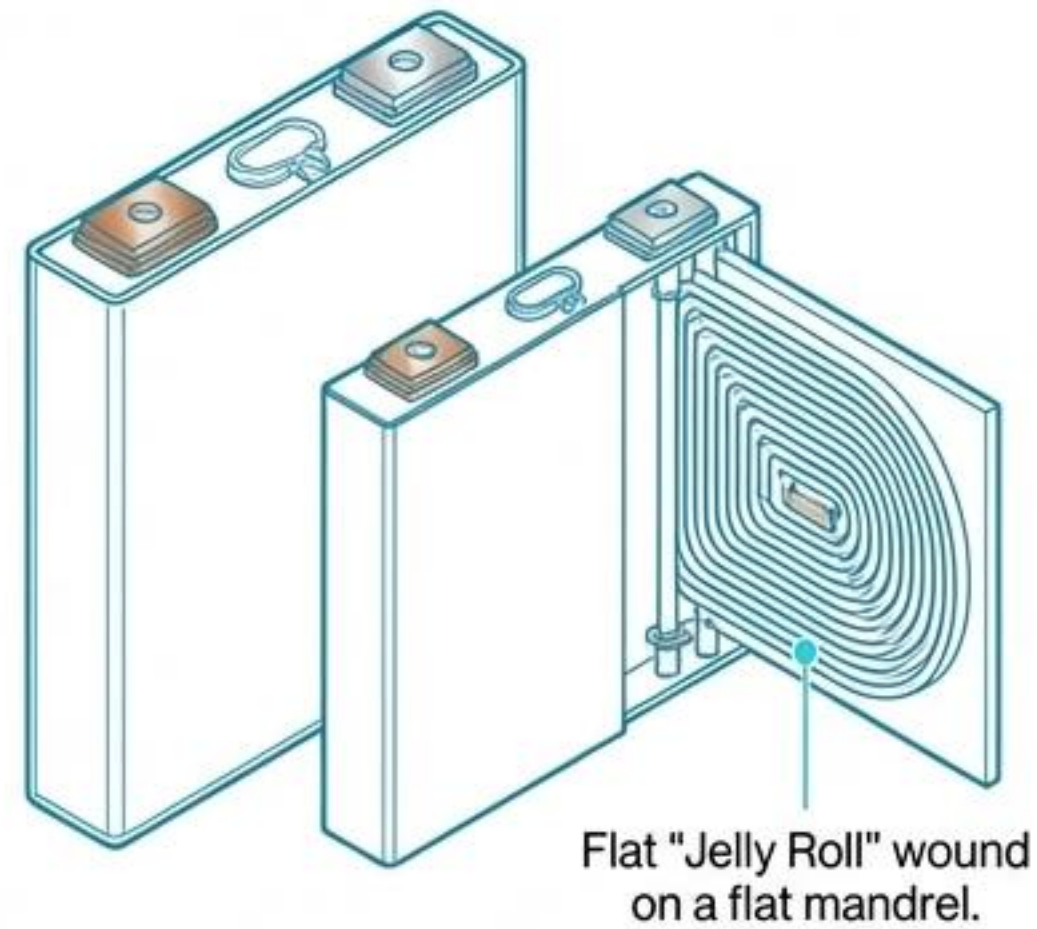

### Characteristics

- Space-efficient, rigid metallic casing, optimized for dense module packaging.

## Pouch Cells

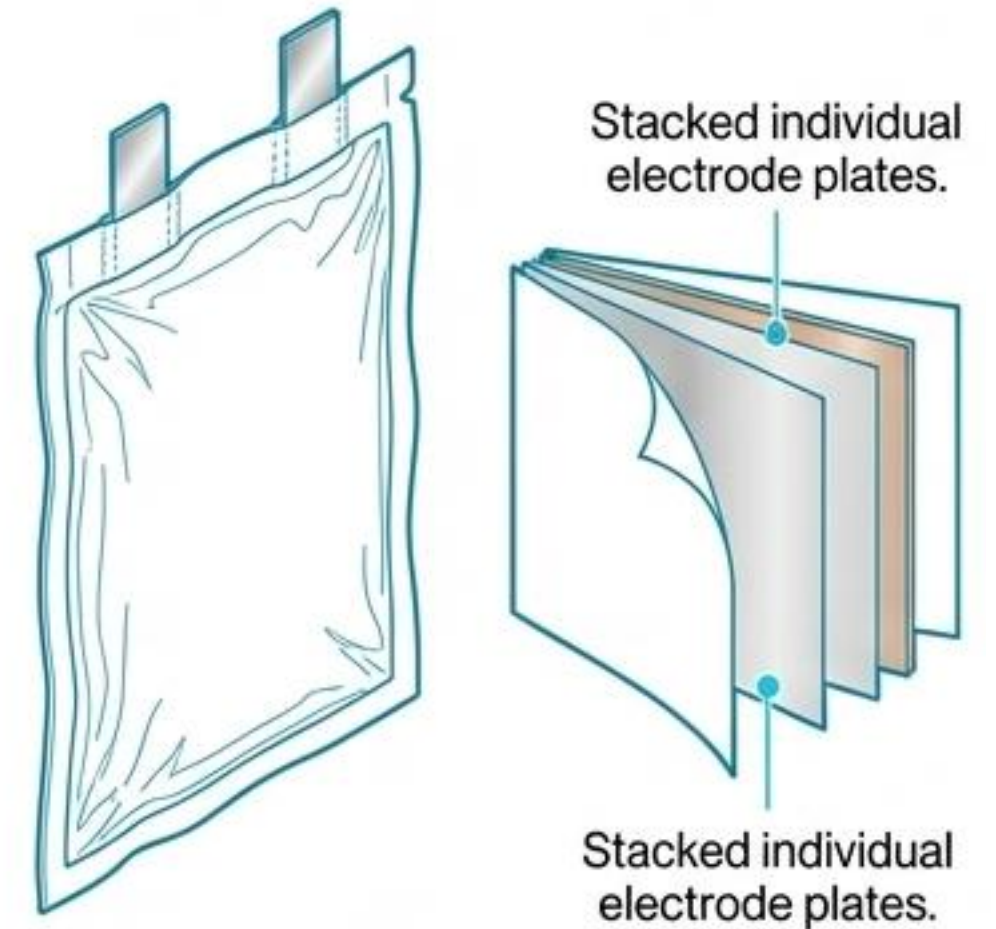

### Characteristics

- Optimizes space for high-capacity applications; flexible outer packaging; susceptible to physical swelling.

# The Electrode Sandwich (Micro-Scale)

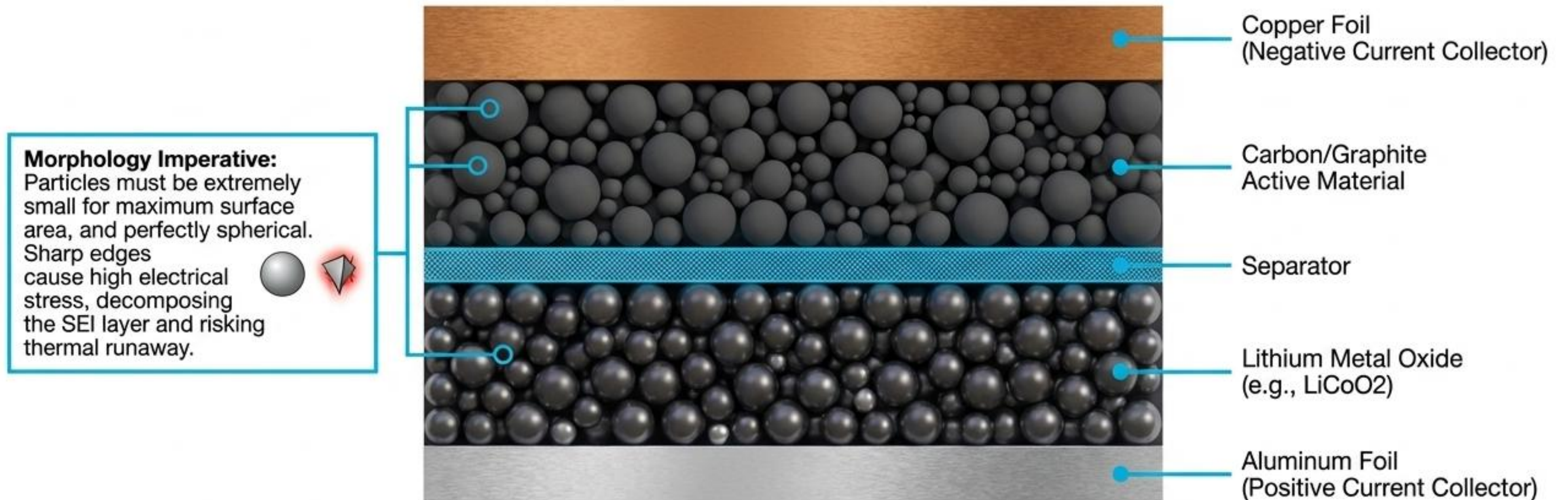

**THE CLEANROOM MANDATE:** Both active materials arrive as nearly indistinguishable black powders. Contamination ruins the cell. Processing must occur in separate, isolated cleanrooms.

# Assembly Types: Winding vs. Stacking

How the processed foils are packed into physical form factors.

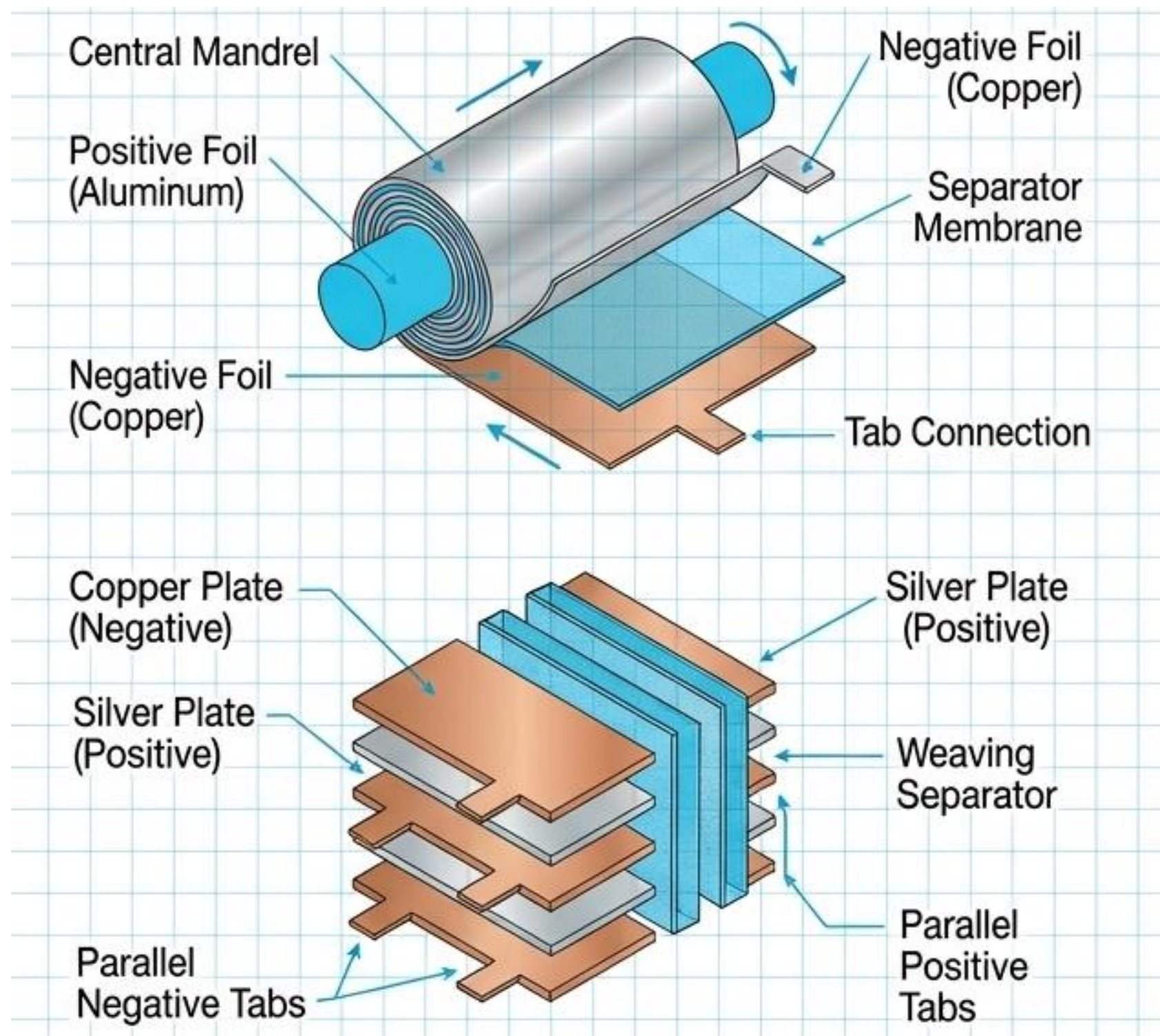

## Spiral Winding (Cylindrical & Prismatic)

Two continuous strips of electrode foil and interleaved separator are wound into a tight spiral. A single tab connects each electrode, though high-power cells use multiple edge tabs to carry higher currents.

## Plate Stacking (Pouch Cells)

Pre-cut individual electrode plates are stacked alternately. A continuous separator weaves between them. All negative tabs are welded in parallel to the negative terminal; all positive tabs are welded in parallel to the positive terminal.

# The Assembly Process Flow



**ENVIRONMENTAL CONTROL:** Cleanroom conditions with strictly controlled access (air showers) are mandatory. Any introduction of ambient dust or physical contaminants during these six physical steps guarantees internal cell failure.

# The Dry Room: Electrolyte Fill & Sealing

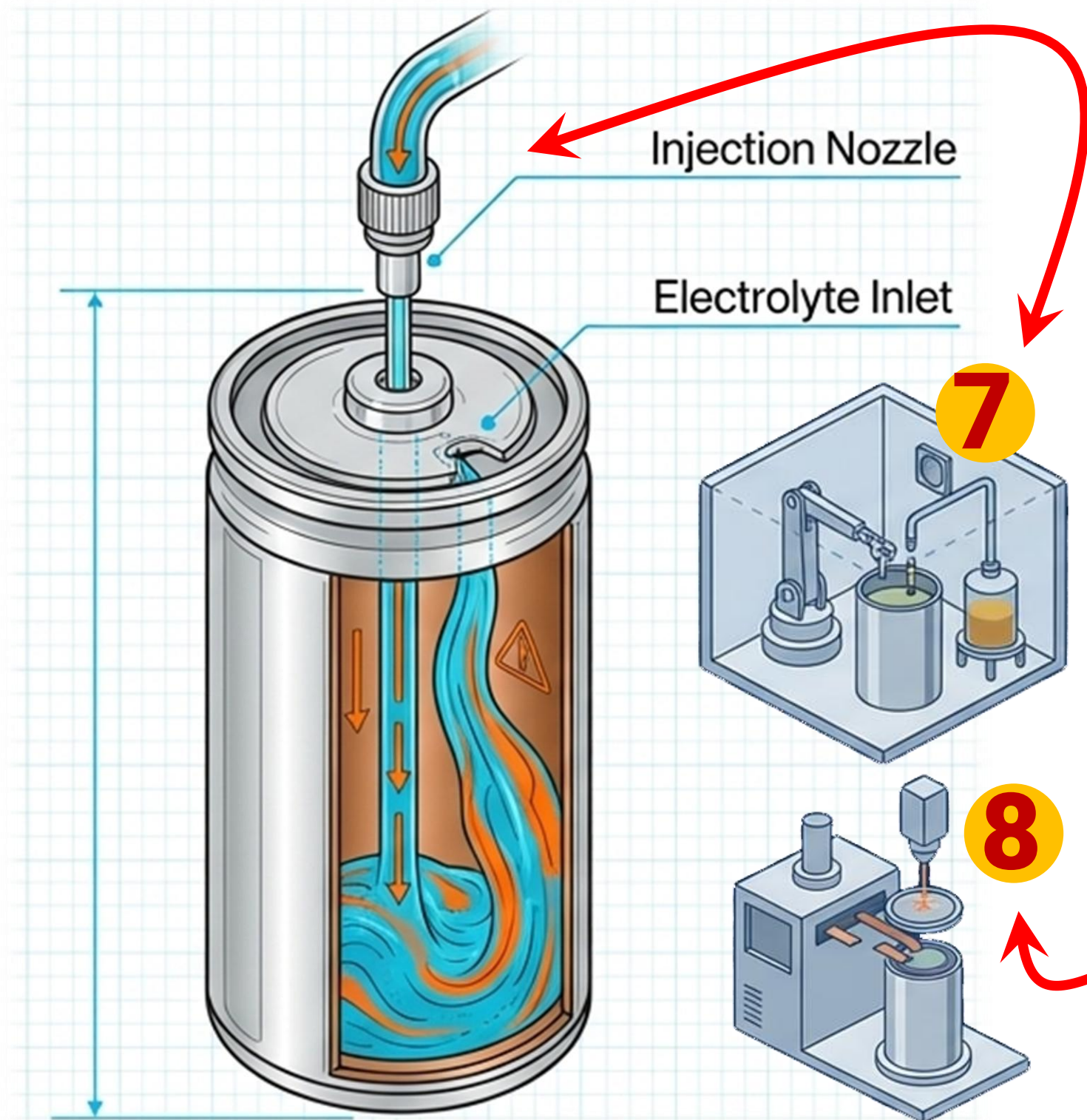

**! DANGER**

**LiPF<sub>6</sub> + H<sub>2</sub>O → HF**  
(Electrolyte) (Moisture) (Toxic Hydrofluoric Acid)

THE DRY ROOM MANDATE: The introduction of the electrolyte is the most chemically dangerous step in manufacturing. It must occur in a strictly controlled “Dry Room” environment with near-zero humidity. Ambient moisture reacts violently with the electrolyte to produce toxic, corrosive hydrofluoric acid gas.

**Final Physical Step:** Following injection, the cell is permanently hermetically sealed (e.g., via a ball sealing process) and labeled with batch/serial identification for traceability.

# Formation: Waking the battery

## Electrochemical Activation

The physical cell is built, but inert. "Formation" is the first, precisely controlled charge/discharge cycle that activates the working materials into their usable states.

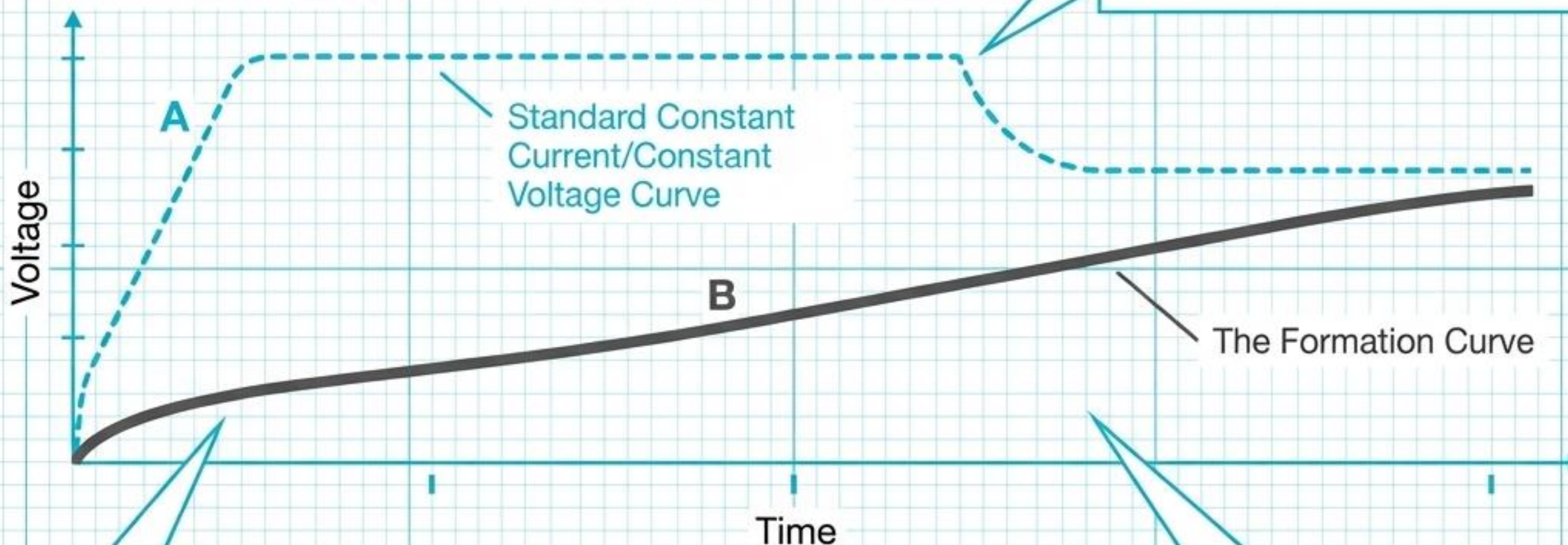

## The SEI Layer

Formation forces the creation of the Solid Electrolyte Interphase (SEI) on the negative electrode—a vital passivating layer essential for moderating all future charging cycles safely.

## Quality Control & Infant Mortalities ⚡

This stage records capacity and impedance, deliberately triggering early failures ("infant mortalities") from latent manufacturing defects while still safely inside the factory.

# Entropy: Overview of Failure Modes

How batteries eventually break down, split into two distinct thermodynamic pathways.

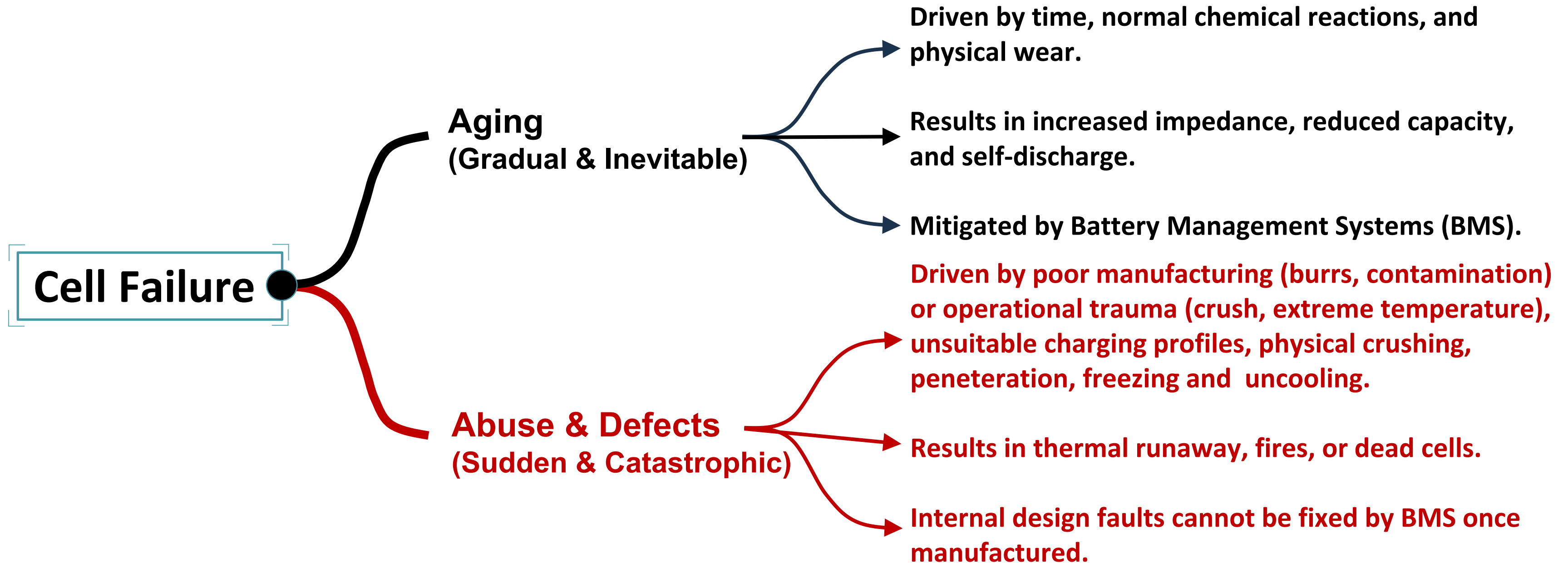

Context: Optimal control systems are designed to manage aging and prevent external abuse, but they are powerless against internal manufacturing defects.

# Aging & Degradation Diagnostics

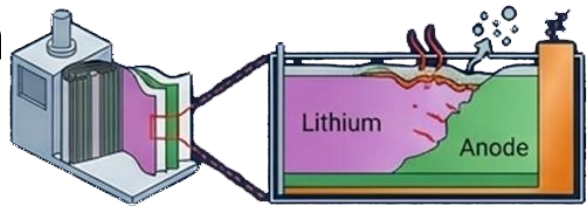
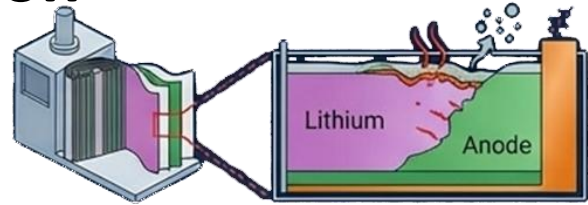
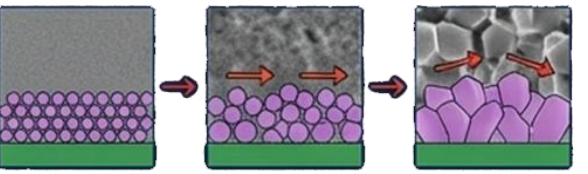
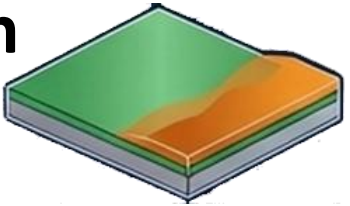
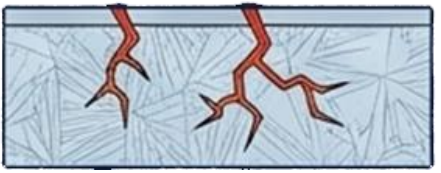
Failure Mechanism	Root Cause	Operational Effect
<b>Corrosion</b> 	<p>Undesired chemical reactions with the surrounding internal environment consume active chemicals.</p>	<p>Gradual capacity loss and increased internal impedance.</p>
<b>Evaporation</b> 	<p>Gaseous loss of electrolyte components resulting from chronic over-charging.</p>	<p>Permanent, unrecoverable capacity loss.</p>
<b>Crystal Formation</b> 	<p>Over time, tiny electrode particles merge into much larger crystalline structures.</p>	<p>Massively reduces effective surface area, crippling current-carrying capacity and spiking impedance.</p>
<b>Passivation</b> 	<p>A resistive layer builds up continuously on the electrodes, acting as a physical barrier to the chemical action.</p>	<p>Increased internal impedance</p>
<b>Swelling &amp; Cracking</b> 	<p>Changing crystal structures physically expand the electrodes, increasing pressure on the separator.</p>	<p>Electrolyte dry-out or physical cracking in solid-state architectures.</p>

**⚠ Note: All of these natural aging processes are permanently accelerated by elevated operating temperatures.**

# Short Circuit Electrical Failures

Dendritic Growth  
(Chemistry Failure)

Slitting Defect (The Burr)  
(Manufacturing Failure)

Dendritic  
Growth

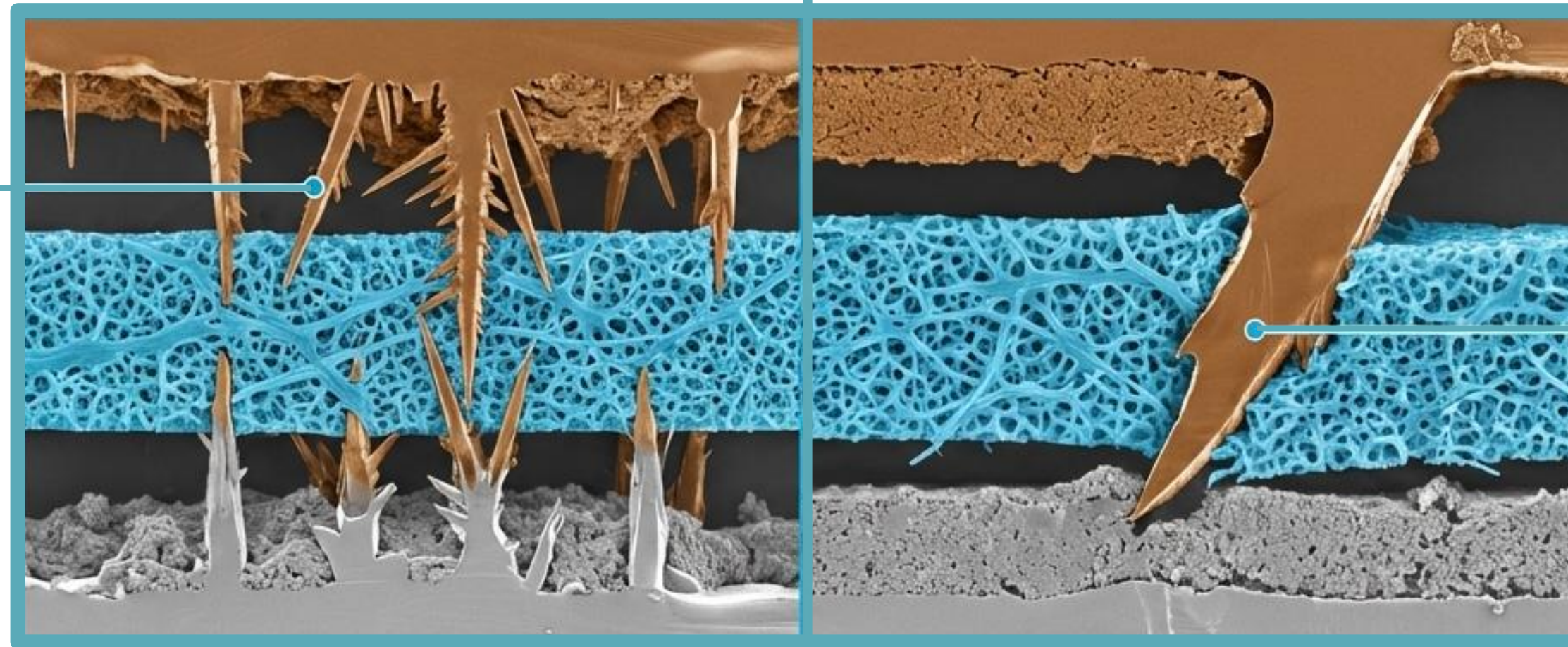

Slitting Defect  
(The Burr)

Soft Short

Hard Short

A small, localized contact point. Sometimes acts like a self-correcting fuse where the high current instantly melts the tiny connection, interrupting the current path.

A solid, unyielding connection causing massive, uncontrolled current flow, resulting in total discharge, permanent cell death, and immediate thermal risk.



**BMS LIMITATION:** A Battery Management System can isolate external electrical shorts, but is completely powerless to stop an internal short circuit once the membrane is pierced.

# The Ultimate Failure: Thermal Runaway

## 1. Trigger

Heat generation (from a hard short, overcharging, or external heat) exceeds the cell's heat dissipation capabilities.

## 4. Acceleration

The reaction generates even more intense heat, feeding directly back into Step 1, triggering neighboring cells.

## 1. Trigger

temperatures (from a non short, melting internal heat) exceeds the cell's heat dissipation capabilities.

## 2. Breakdown

Internal temperatures spike, melting the separator and breaking down the SEI layer and electrolyte.

## 3. Reaction

Toxic, flammable gases are released, and violent exothermic chemical reactions ignite.

**The Core Principle:** The rate of internal chemical reactions tends to double for every 10°C increase in temperature.



**THE IMPERATIVE OF CONTROL:** Thermal runaway is a thermodynamic point of no return. The ultimate goal of all battery engineering and Battery Management Systems (BMS) is to actively monitor thermal boundaries, prevent physical abuse, and manage current output to keep the cell safely confined within its designed operating window.

**Takeaway:** Once thermal runaway achieves positive feedback, it cannot be stopped by the Battery Management System (BMS); it must physically burn out.



razeghizade@gmail.com

Razeghizade.pudica.ir

**CREADITS:** This presentation was created by M.Razeghizadeh, a faculty member of the Electrical Engineering Department at Iran University of Science and Technology, and all material and intellectual property rights are reserved by him.

**[Please keep this slide for attribution]**