

Microcontrollers

Lecture 7:

Timer/counter (Wave Generating And Capturing)

By: M.Razeghizadeh

Start now!



Contents of This Slide

- Wave characteristics
 - Music and frequencies
- Timer0 review
- Wave generating using Timer0
- Wave generating using Timer2
- Wave generating using Timer1
- Capturing

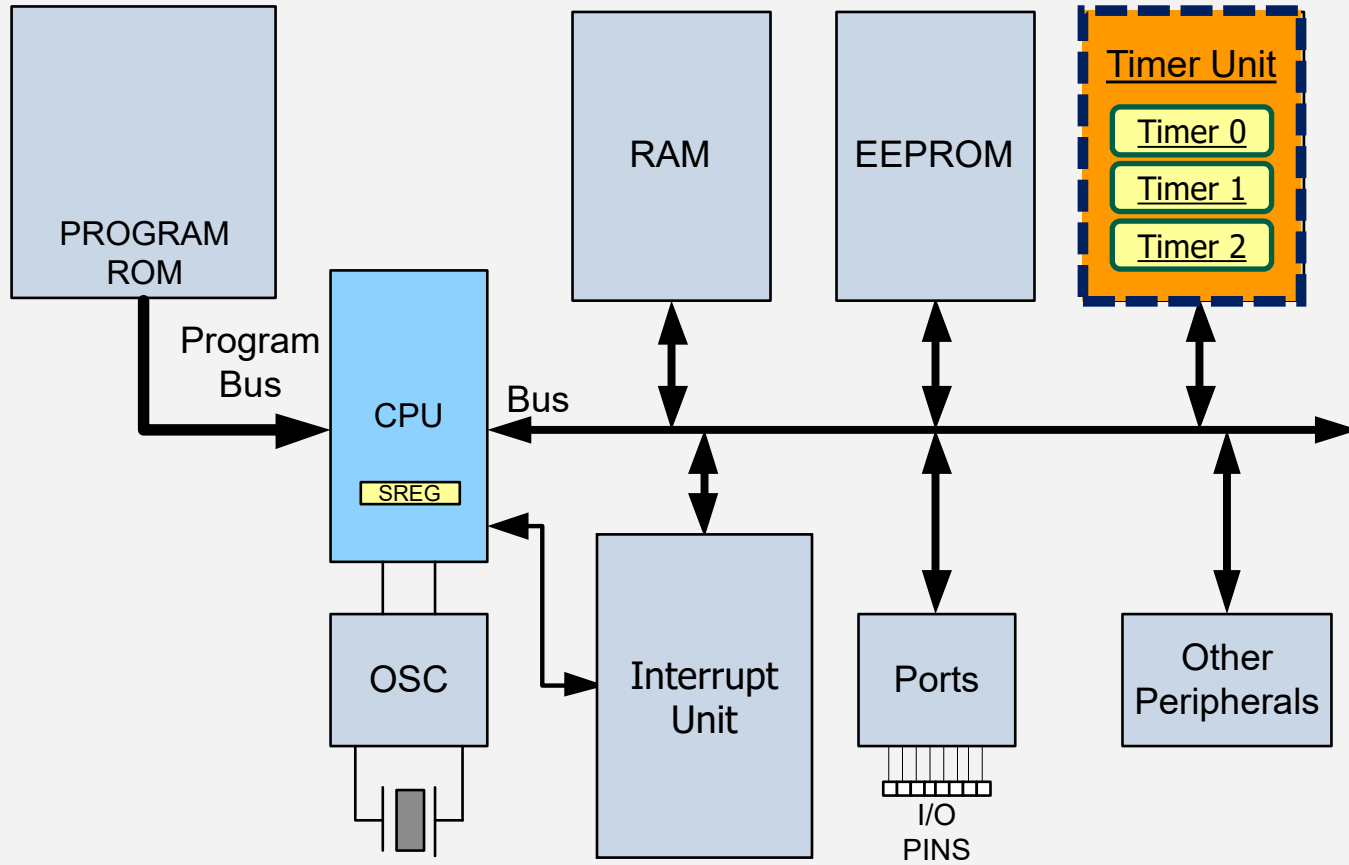



■ Period

- Frequency

$$f = \frac{1}{T}$$

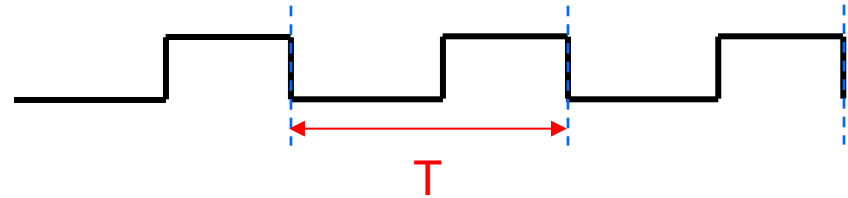

■ Duty cycle

$$\text{duty cycle} = \frac{t_0}{T} \times 100 = \frac{t_0}{t_0 + t_1} \times 100$$

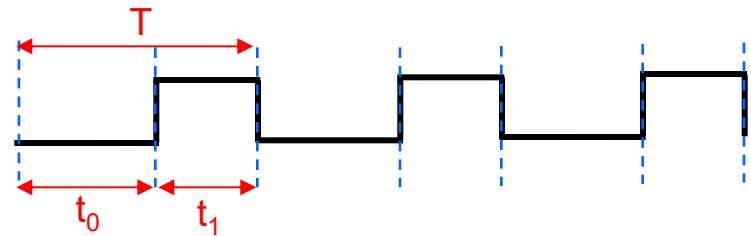

■ Amplitude



Music

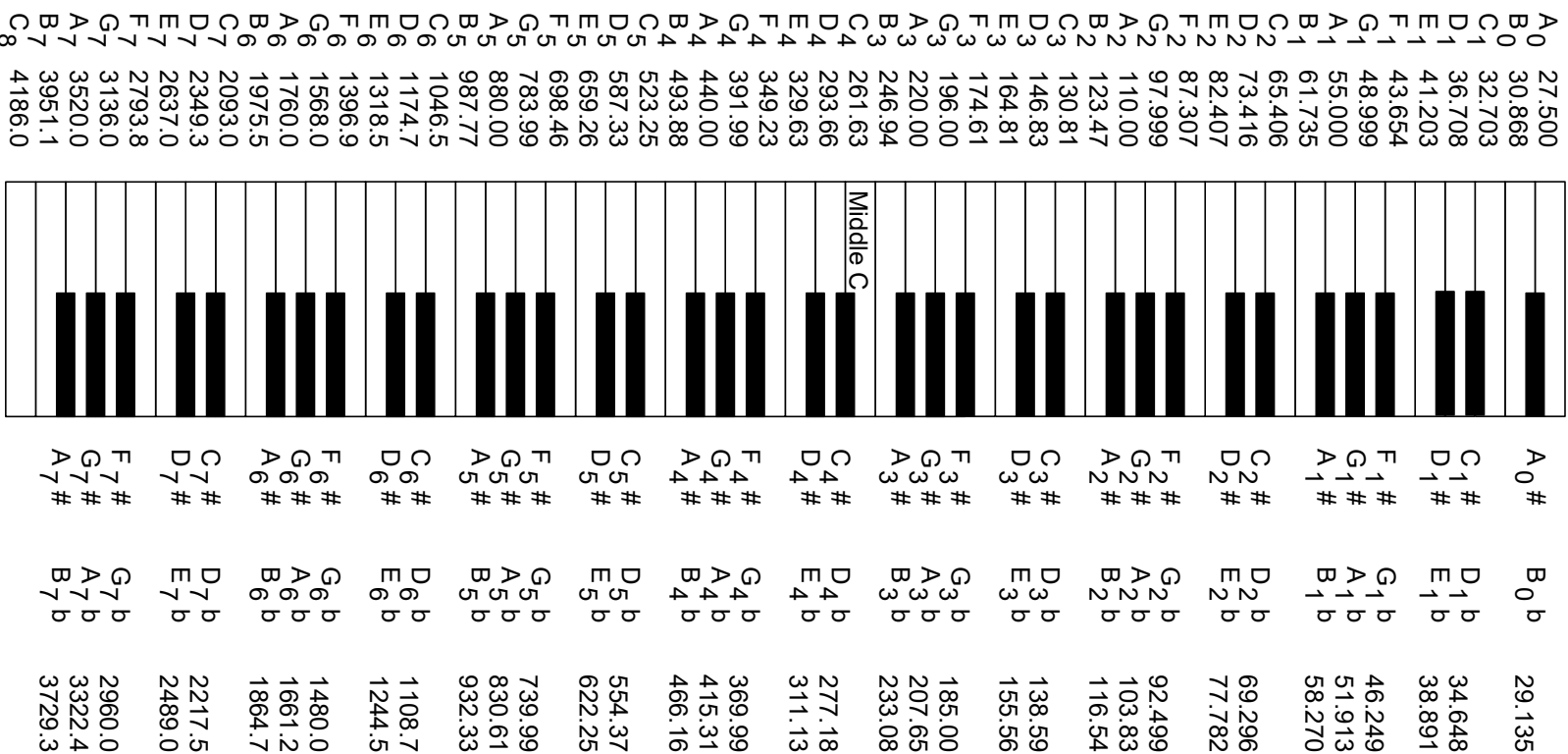

3-5. Piano Note Frequencies



Sine

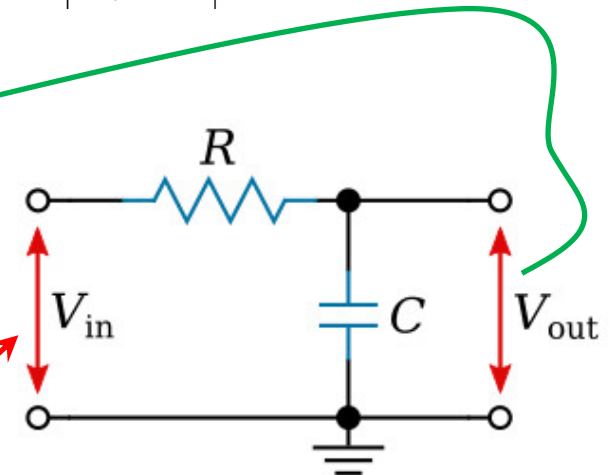
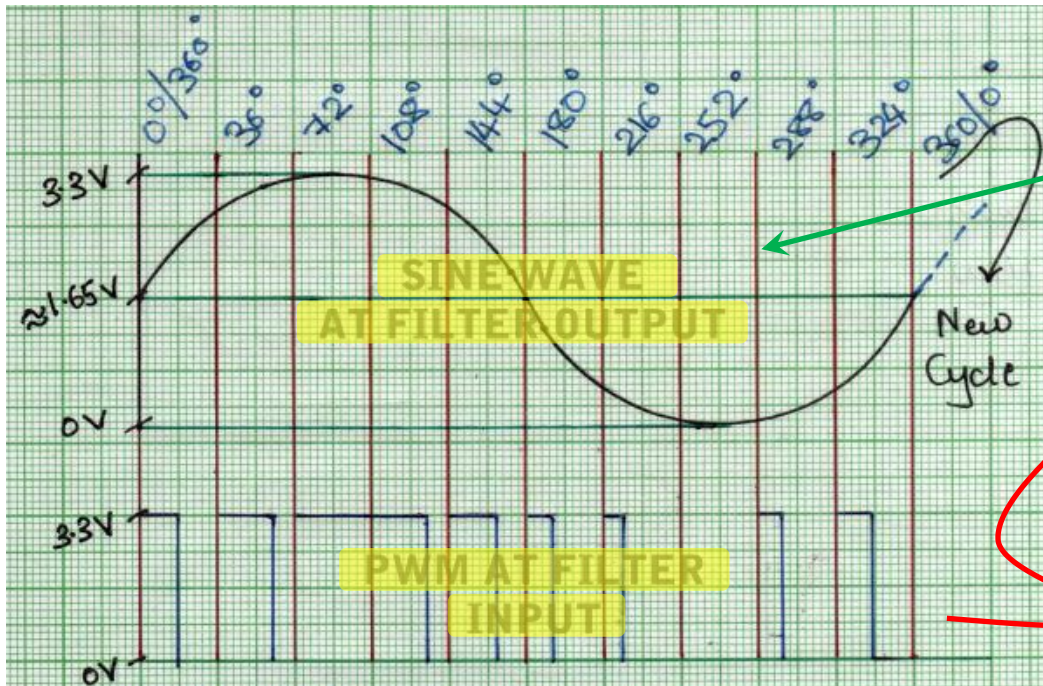
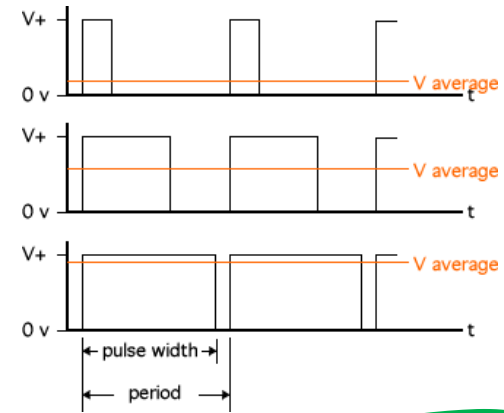
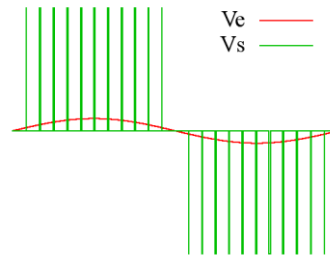



Waveform generators in ATmega328

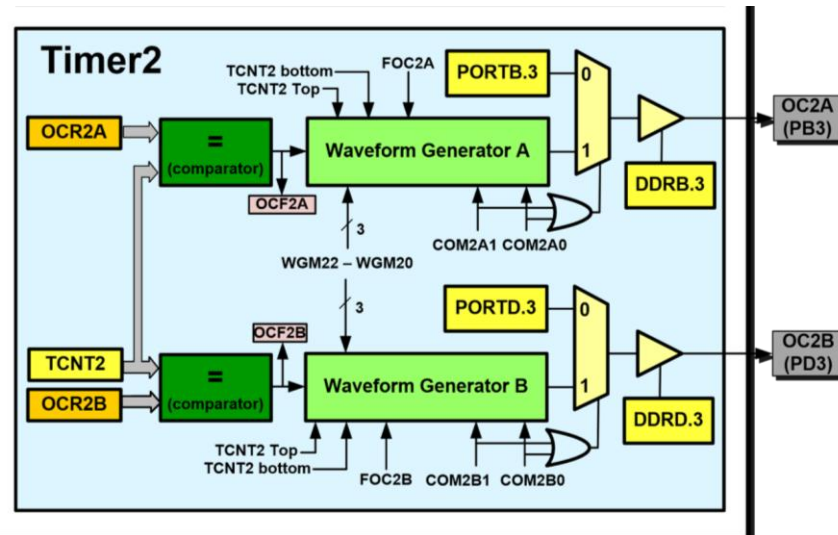
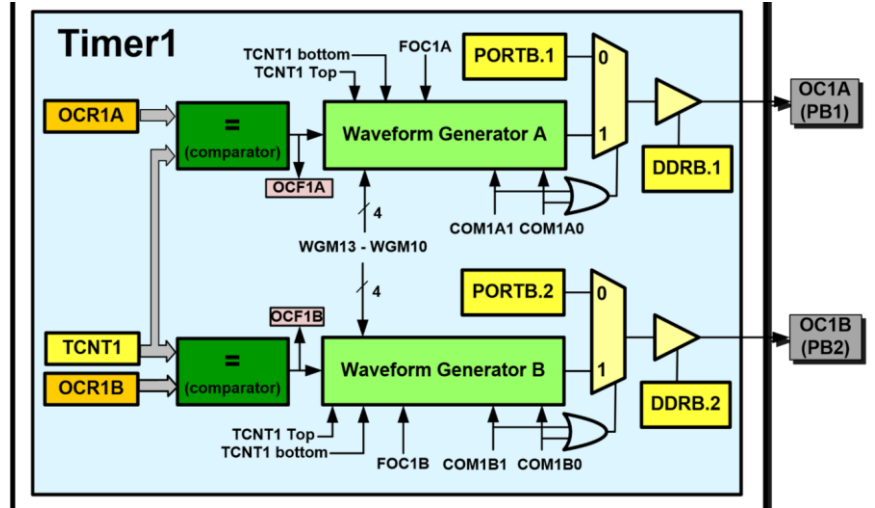
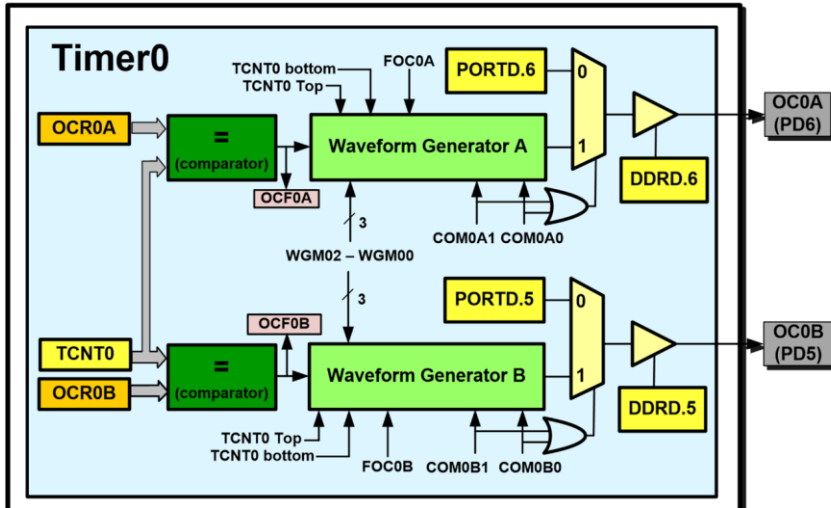



Waveform generators in ATmega328

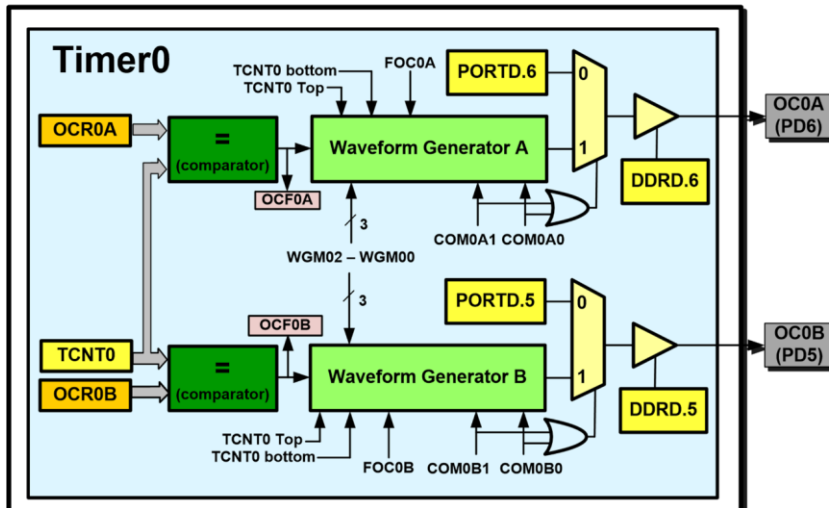

(PCINT14/RESET) PC6	1	28	PC5 (ADC5/SCL/PCINT13)
(PCINT16/RXD) PD0	2	27	PC4 (ADC4/SDA/PCINT12)
(PCINT17/TXD) PD1	3	26	PC3 (ADC3/PCINT11)
(PCINT18/INT0) PD2	4	25	PC2 (ADC2/PCINT10)
(PCINT19/OC2B/INT1) PD3	5	24	PC1 (ADC1/PCINT9)
(PCINT20/XCK/T0) PD4	6	23	PC0 (ADC0/PCINT8)
VCC	7	22	GND
GND	8	21	AREF
(PCINT6/XTAL1/TOSC1) PB6	9	20	AVCC
(PCINT7/XTAL2/TOSC2) PB7	10	19	PB5 (SCK/PCINT5)
(PCINT21/OC0B/T1) PD5	11	18	PB4 (MISO/PCINT4)
(PCINT22/OC0A/AIN0) PD6	12	17	PB3 (MOSI/OC2A/PCINT3)
(PCINT23/AIN1) PD7	13	16	PB2 (\overline{SS} /OC1B/PCINT2)
(PCINT0/CLKO/ICP1) PB0	14	15	PB1 (OC1A/PCINT1)

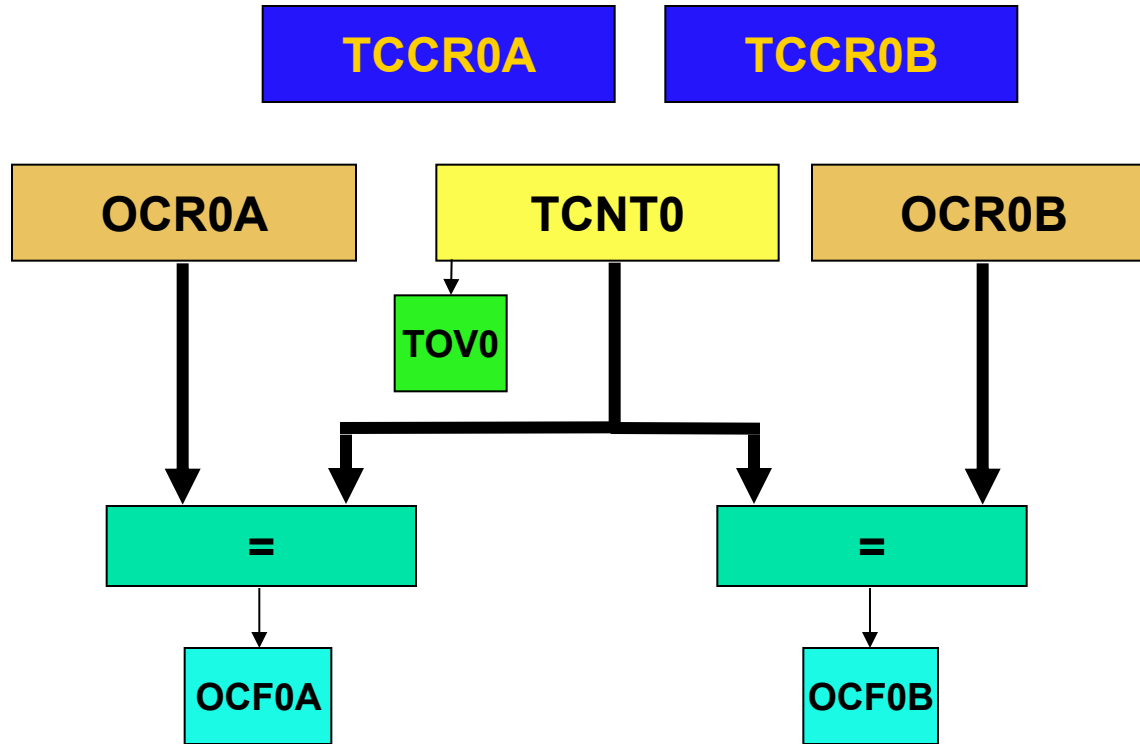

COM0A1	COM0A0	COM0B1	COM0B0	-	-	WGM01	WGM00	TCCR0A
FOC0A	FOC0B	-	-	WGM02	CS02	CS01	CS00	TCCR0B

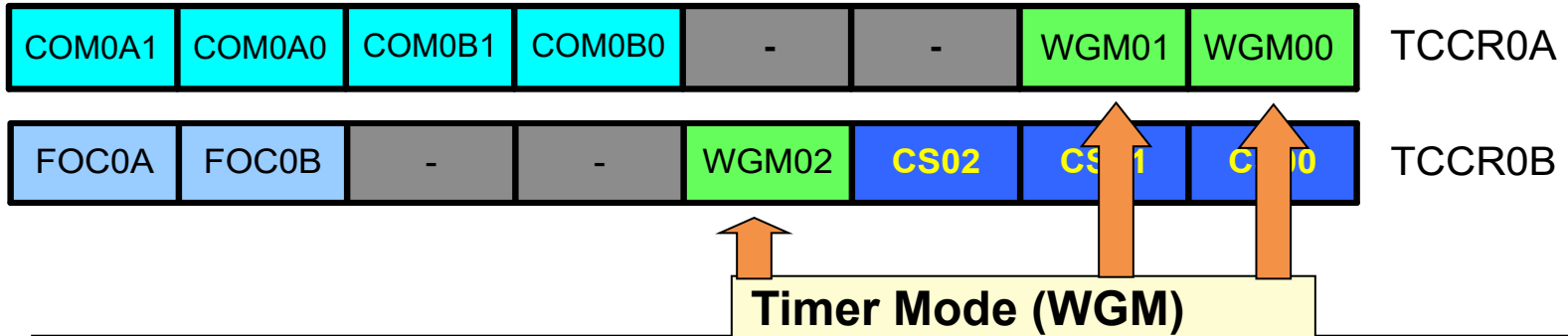

WGM02	WGM01	WGM00	Comment
0	0	0	Normal
0	0	1	Phase correct PWM
0	1	0	CTC (Clear Timer on Compare Match)
0	1	1	Fast PWM
1	0	0	Reserved
1	0	1	Phase correct PWM
1	1	0	Reserved
1	1	1	Fast PWM



Normal mode

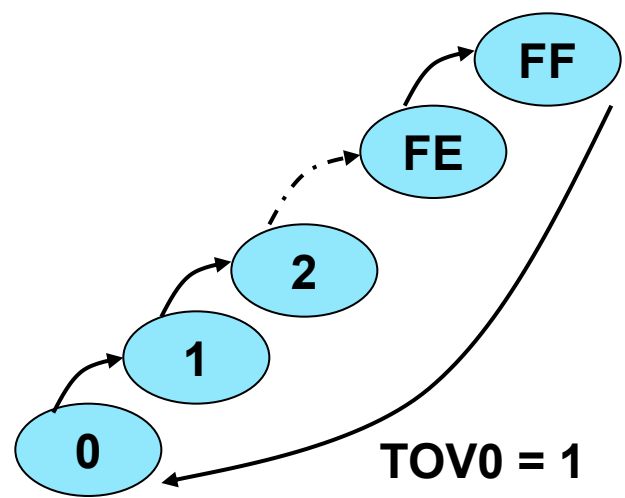
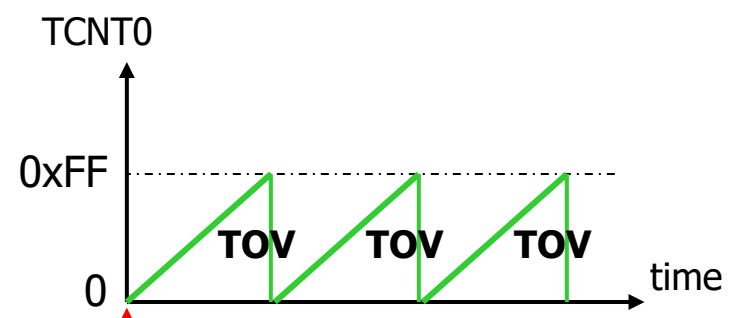

TOV0: 1



CTC (Clear Timer on Compare match) mode

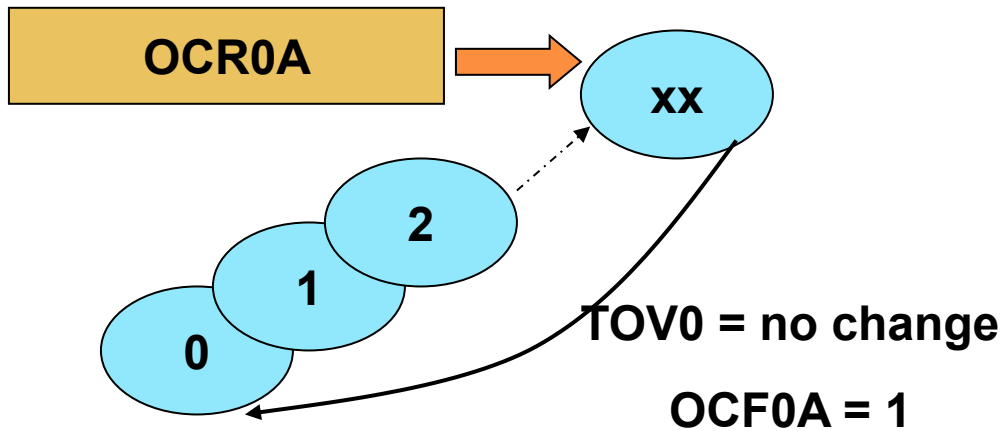
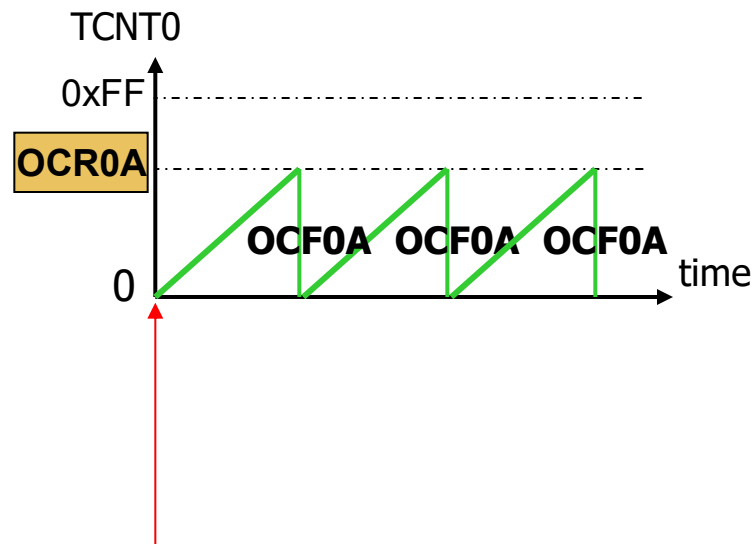



Waveform Generator

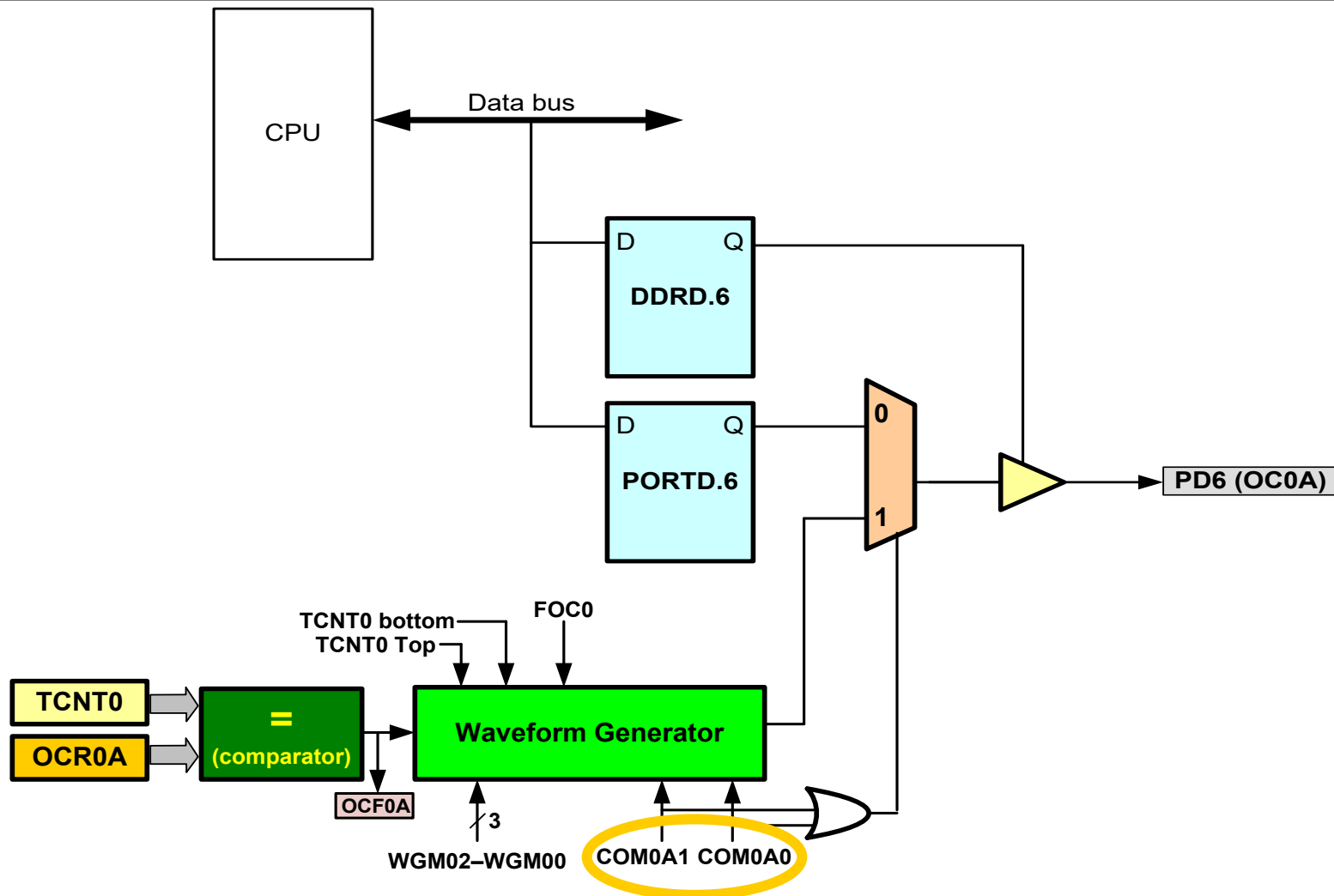



Waveform Generator

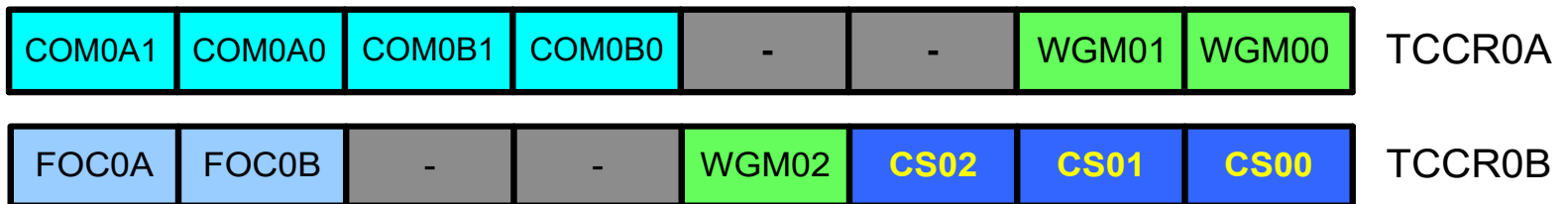
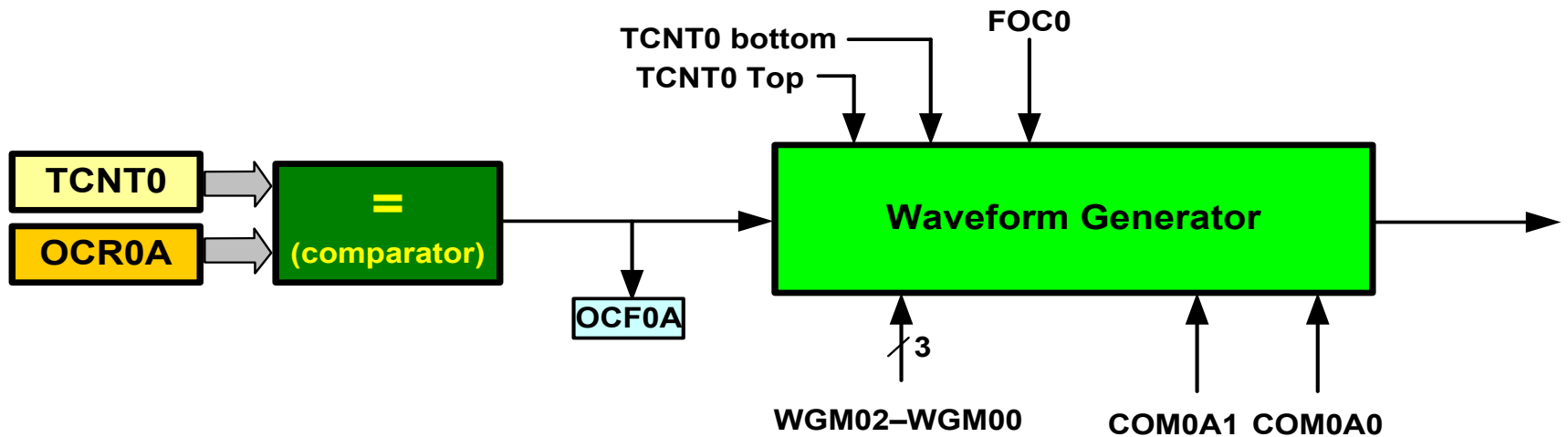



Waveform Generator

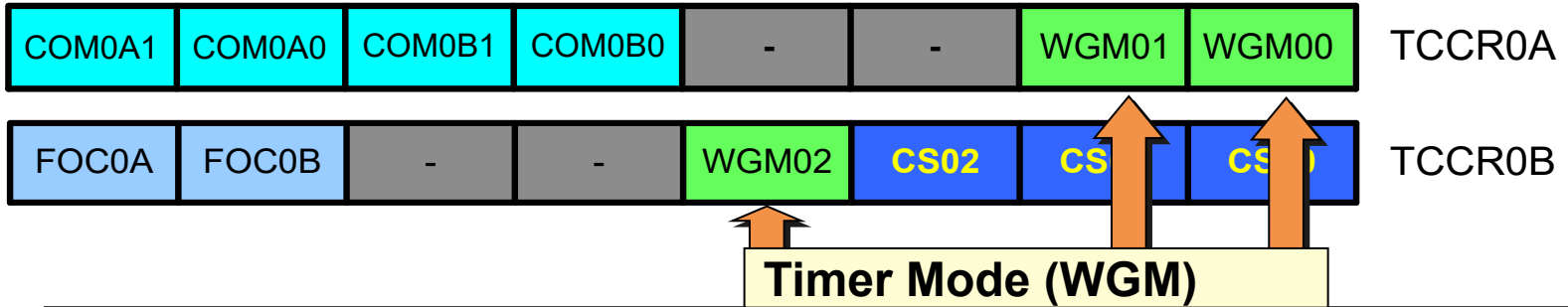

WGM02	WGM01	WGM00	Comment
0	0	0	Normal
0	0	1	Phase correct PWM
0	1	0	CTC (Clear Timer on Compare Match)
0	1	1	Fast PWM
1	0	0	Reserved
1	0	1	Phase correct PWM
1	1	0	Reserved
1	1	1	Fast PWM

COM0x1	COM0x0	Description
0	0	Normal port operation, OC0 disconnected
0	1	Toggle OC0 on compare match
1	0	Clear OC0 on compare match
1	1	Set OC0 on compare match



Waveform Generator

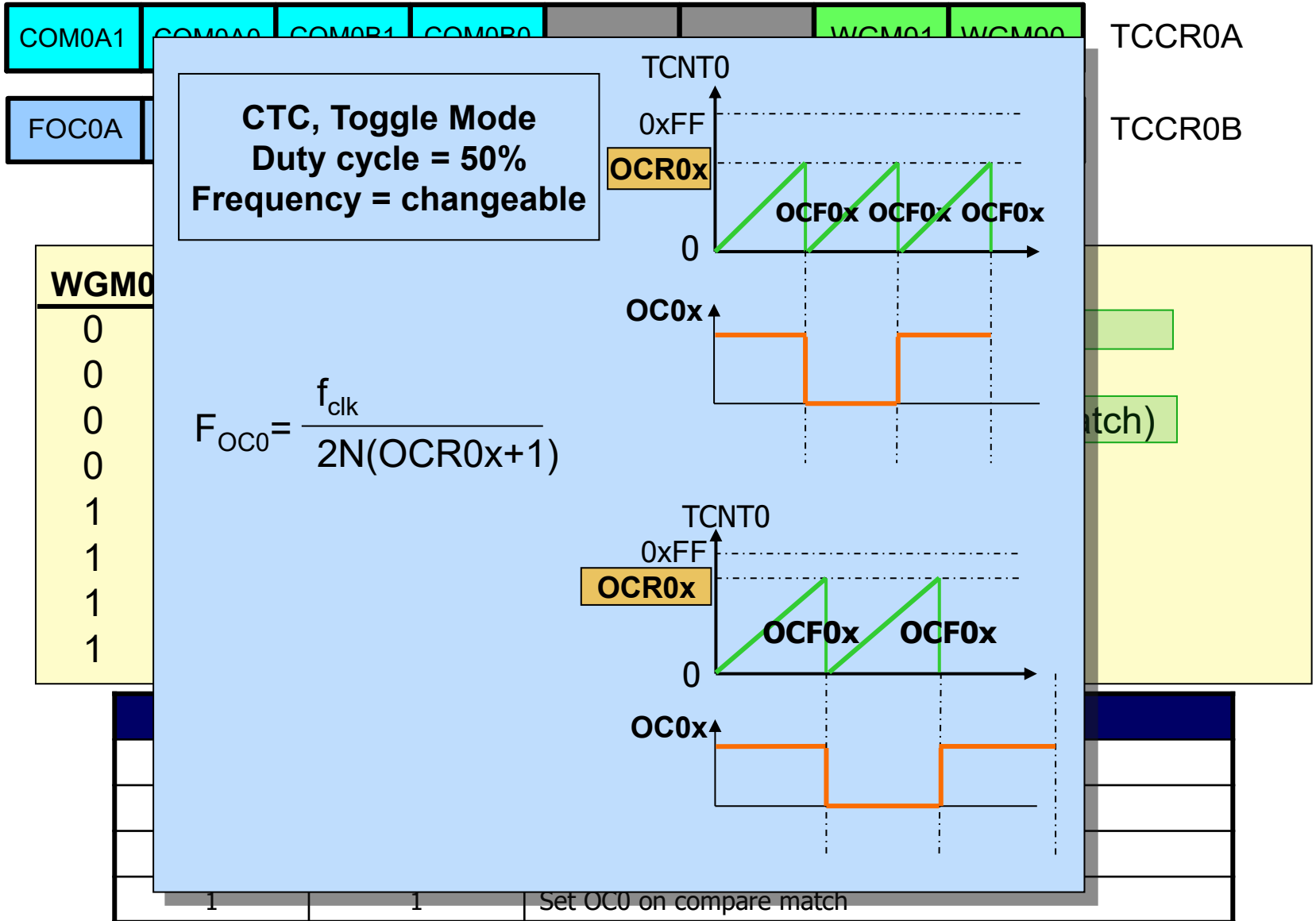



Assuming XTAL = 16 MHz, make a pulse with
duty cycle = 50% and frequency = 1MHz

$$F_{\text{OCO}} = \frac{f_{\text{clk}}}{2N(\text{OCR0x}+1)} \Rightarrow 1\text{MHz} = \frac{16\text{MHz}}{2N(\text{OCR0x}+1)} \Rightarrow N(\text{OCR0x}+1) = \frac{16\text{MHz}}{2\text{MHz}}$$

$$\Rightarrow N(\text{OCR0}+1) = 8 \Rightarrow \begin{cases} N = 1 \text{ and } \text{OCR0} = 7 \\ N = 8 \text{ and } \text{OCR0} = 0 \end{cases}$$

```
OCR0A = 7;
```

```
TCCR0A = (1<<COM0A0) | (1<<WGM01); //toggle, CTC
```

```
TCCR0B = 0x01; //prescaler = 1
```

```
OCR0A = 0;
```

```
TCCR0A = (1<<COM0A0) | (1<<WGM01); //toggle, CTC
```

```
TCCR0B = 0x02; //prescaler = 8
```



Wave generating using Timer2

- Like Timer0

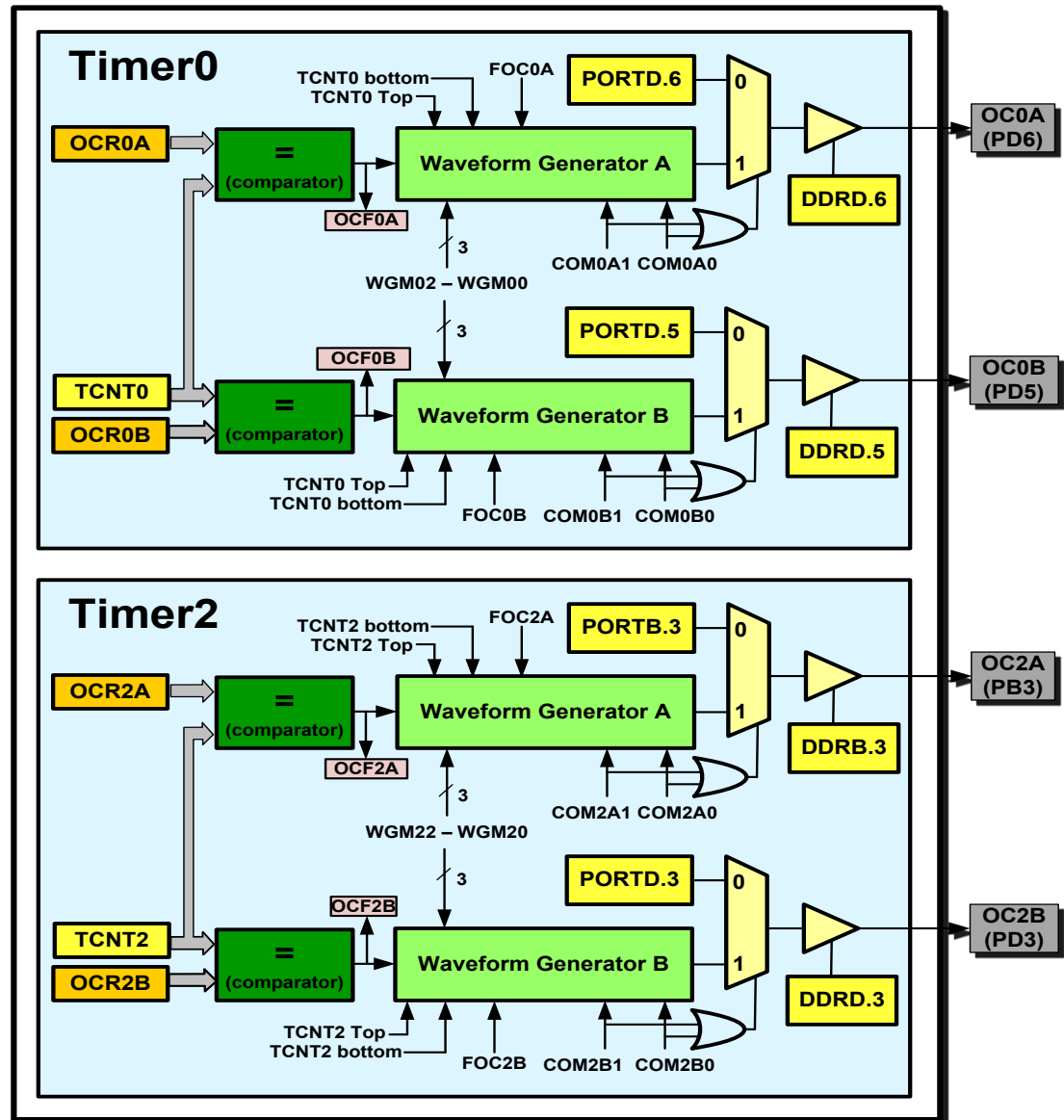



The difference between Timer0 and Timer2

■ Timer0

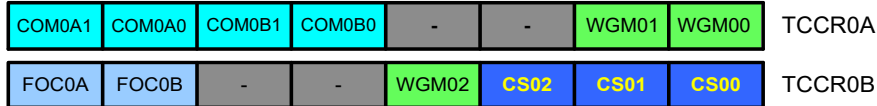

■ Timer2

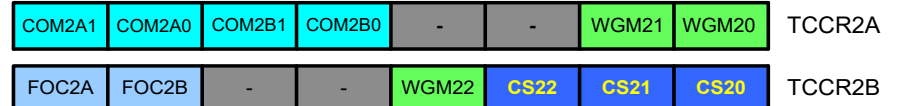

CS02	CS01	CS00	Comment
0	0	0	Timer/Counter stopped
0	0	1	clk (No Prescaling)
0	1	0	clk / 8
0	1	1	clk / 64
1	0	0	clk / 256
1	0	1	clk / 1024
1	1	0	External clock (falling edge)
1	1	1	External clock (rising edge)

CS22	CS21	CS20	Comment
0	0	0	Timer/Counter stopped
0	0	1	clk (No Prescaling)
0	1	0	clk / 8
0	1	1	clk / 32
1	0	0	clk / 64
1	0	1	clk / 128
1	1	0	clk / 256
1	1	1	clk / 1024



Timer1 has two waveform generators

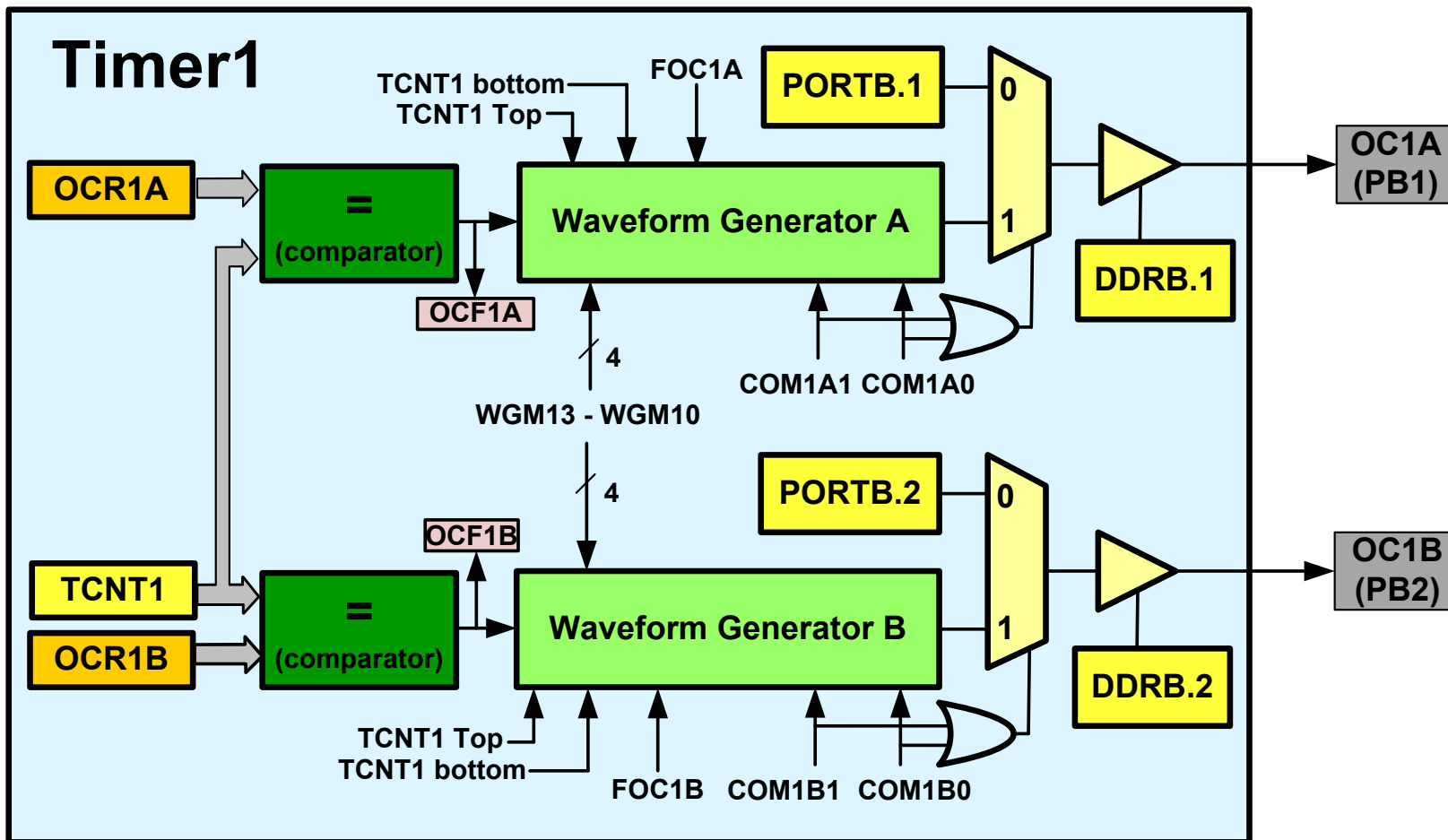

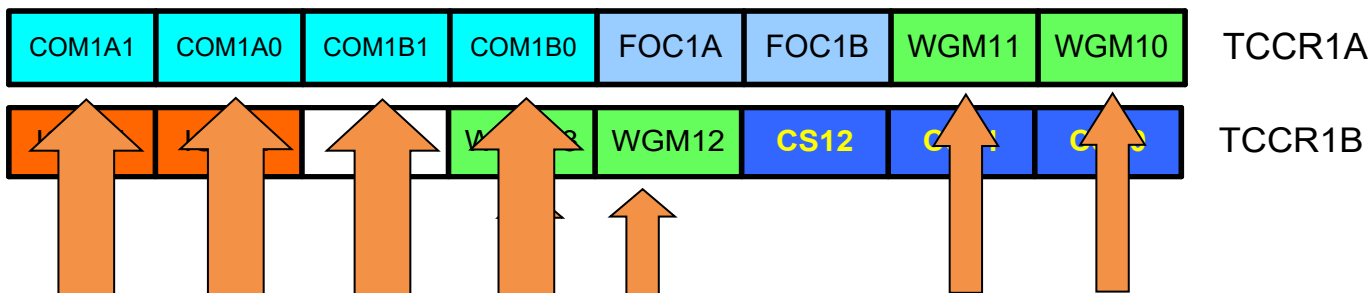

In non PWM modes

COM1A1:COM1A0 D7 D6 Compare Output Mode for Channel A

COM1A1	COM1A0	Description
0	0	Normal port operation, OC1A disconnected
0	1	Toggle OC1A on compare match
1	0	Clear OC1A on compare match
1	1	Set OC1A on compare match

COM1B1:COM1B0 D5 D4 Compare Output Mode for Channel B

COM1B1	COM1B0	Description
0	0	Normal port operation, OC1B disconnected
0	1	Toggle OC1B on compare match
1	0	Clear OC1B on compare match
1	1	Set OC1B on compare match



■ Usages

- Measuring duty cycle
- Measuring period

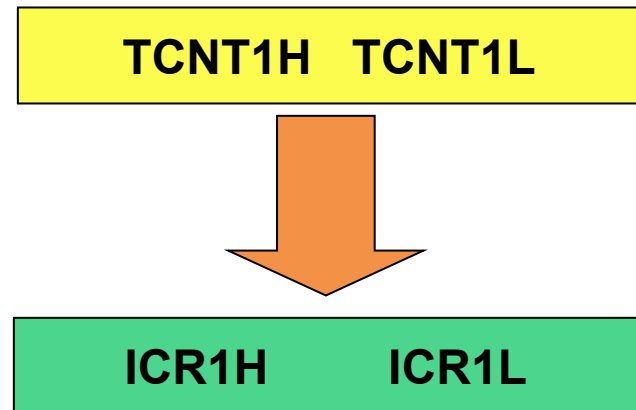

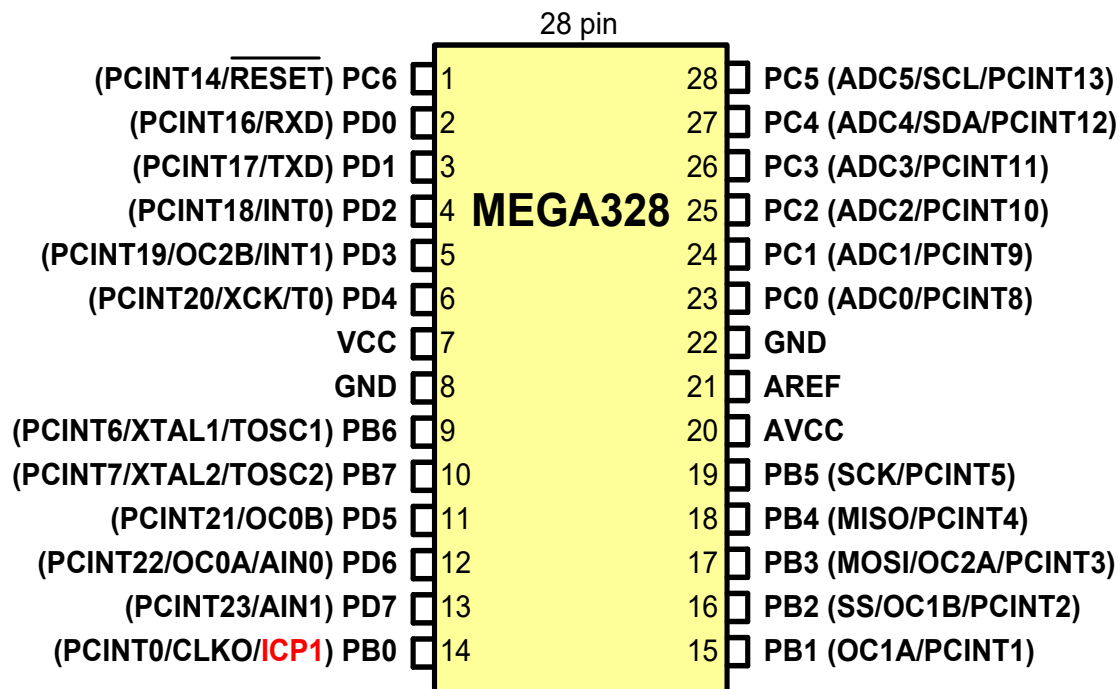
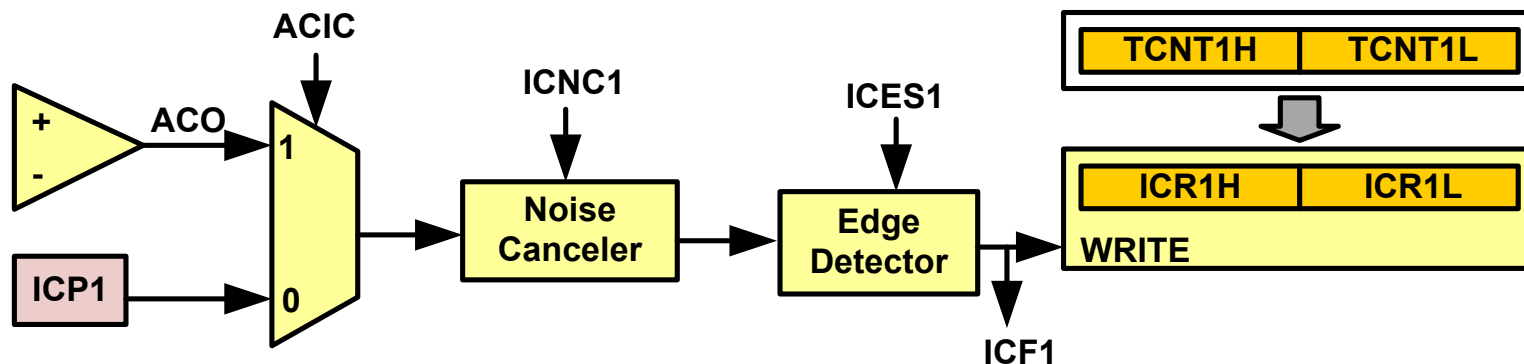



Comparator

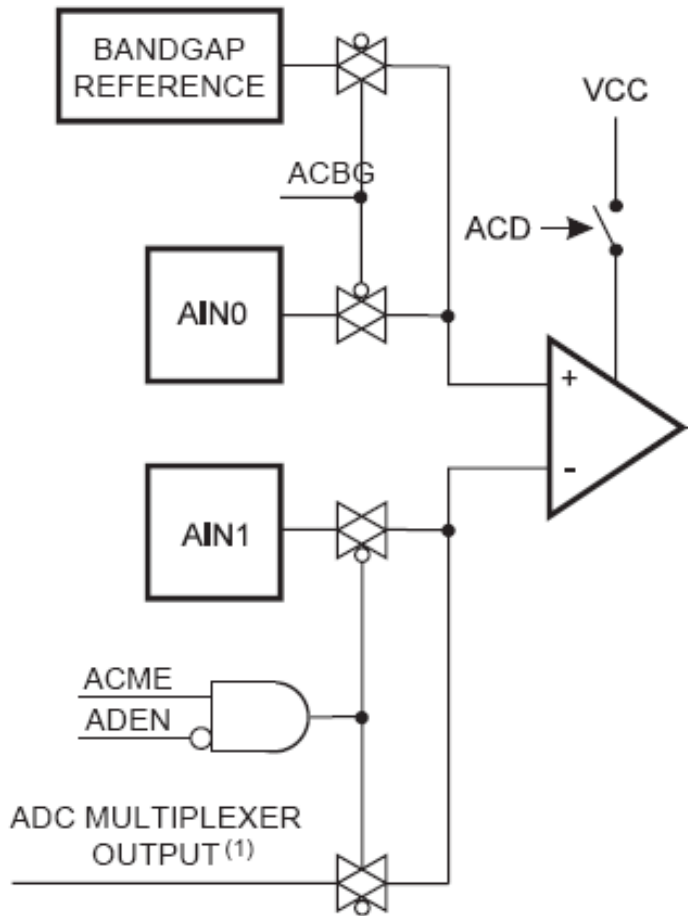

28 pin

(PCINT14/RESET) PC6	1	28	PC5 (ADC5/SCL/PCINT13)
(PCINT16/RXD) PD0	2	27	PC4 (ADC4/SDA/PCINT12)
(PCINT17/TXD) PD1	3	26	PC3 (ADC3/PCINT11)
(PCINT18/INT0) PD2	4	25	PC2 (ADC2/PCINT10)
(PCINT19/OC2B/INT1) PD3	5	24	PC1 (ADC1/PCINT9)
(PCINT20/XCK/T0) PD4	6	23	PC0 (ADC0/PCINT8)
VCC	7	22	GND
GND	8	21	AREF
(PCINT6/XTAL1/TOSC1) PB6	9	20	AVCC
(PCINT7/XTAL2/TOSC2) PB7	10	19	PB5 (SCK/PCINT5)
(PCINT21/OC0B) PD5	11	18	PB4 (MISO/PCINT4)
(PCINT22/OC0A/AIN0) PD6	12	17	PB3 (MOSI/OC2A/PCINT3)
(PCINT23/AIN1) PD7	13	16	PB2 (SS/OC1B/PCINT2)
(PCINT0/CLKO/ICP1) PB0	14	15	PB1 (OC1A/PCINT1)

MEGA328

Copied from ATmega328P datasheet page 239

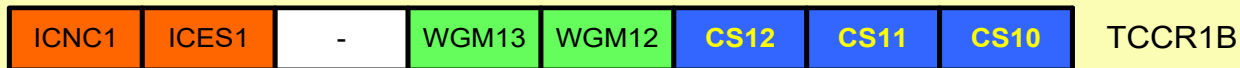
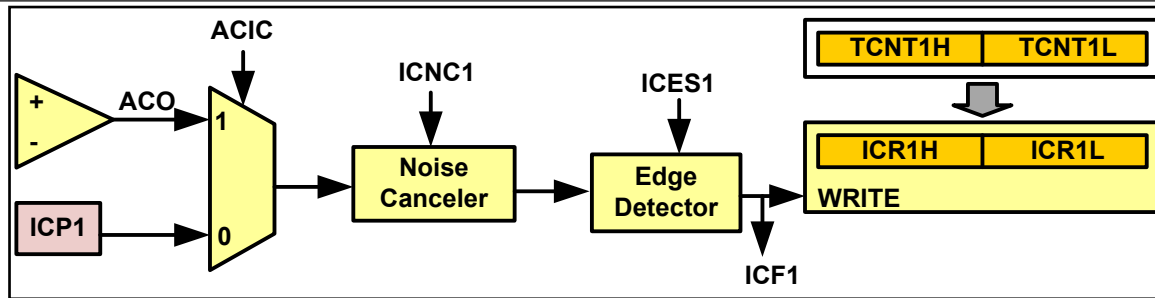

ICNC1: Input Capture Noise Canceller
 0: disabled
 1: Enabled (captures after 4 successive equal valued samples)

ICES1: Input Capture Edge Select
 0: Falling edge
 1: Rising edge

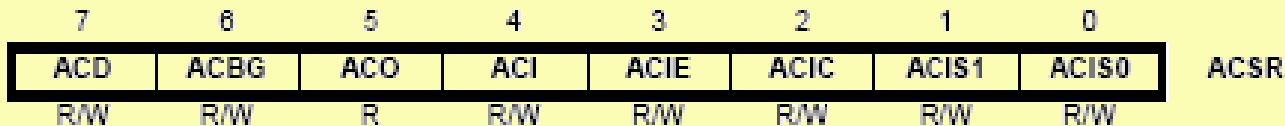

ACIC: Analog Comparator Input Capture Enable
 0: ICP1 provides the capture signal
 1: analog comparator is connected to the capturer



Measuring duty cycle and period

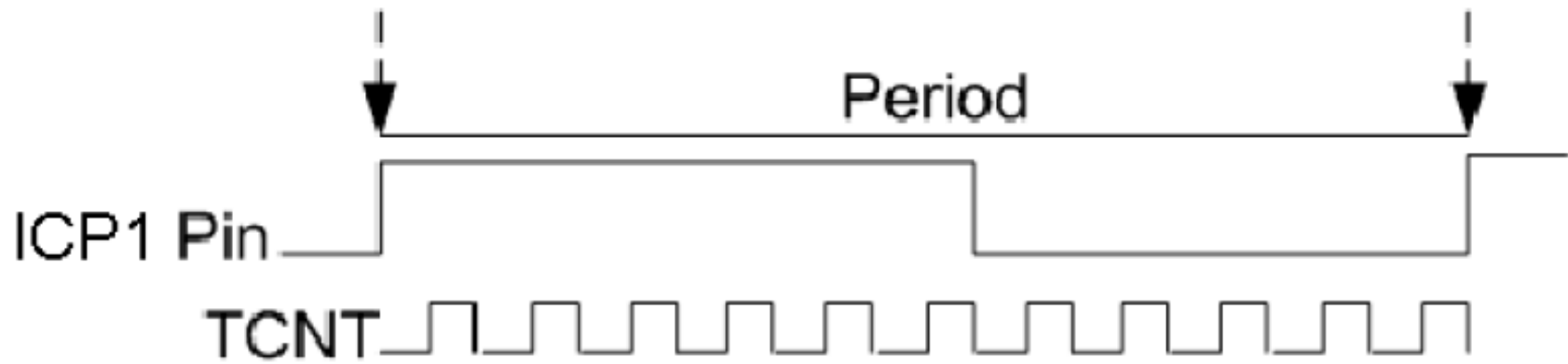

Measuring Period in Terms of the Number of Clocks Counted By TCNT

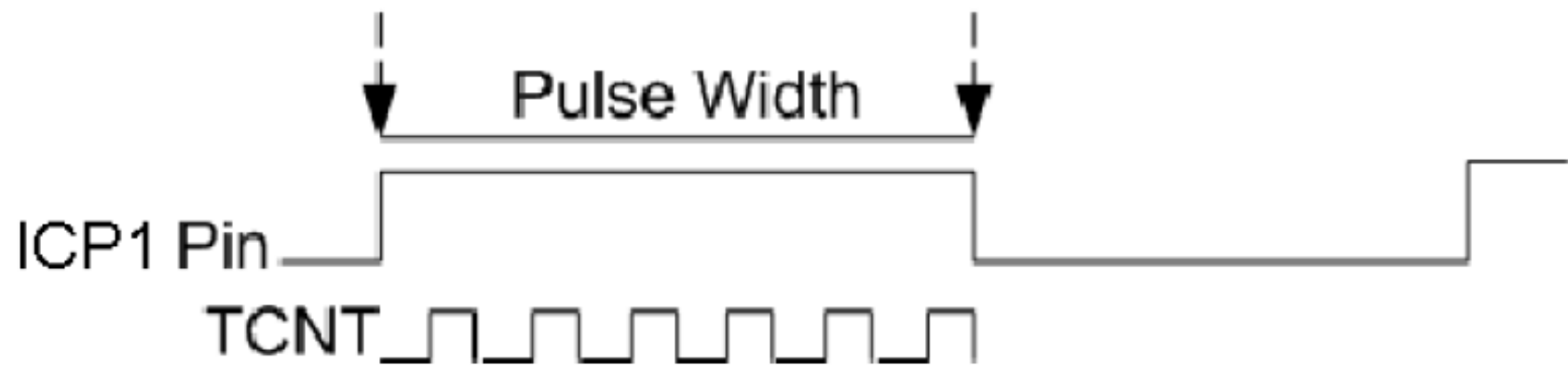

Measuring Pulse Width in Terms of the Number of Clocks Counted By TCNT



Example: Measuring the frequency of a wave which is between 1 μs and 250 μs .

```
#include <avr/io.h>

int main ( )
{
    unsigned char t1;

    DDRD = 0xFF; //Port D as output
    PORTB |= (1<<0);

    TCCR1A = 0; //Timer Mode = Normal
    TCCR1B = 0x42; //rising edge, prescaler = 8, no noise canc.

    while ((TIFR1&(1<<ICF1)) == 0);

    t1 = ICR1L;
    TIFR1 = (1<<ICF1); //clear ICF1 flag
    TCCR1B = 0x02; //falling edge

    while ((TIFR1&(1<<ICF1)) == 0);

    PORTD = ICR1L - t1; //pulse width = falling - rising
    TIFR1 = (1<<ICF1); //clear ICF1 flag

    while (1); //wait forever
    return 0;
}
```



Thanks!



Do you have any questions?

razeghizade@gmail.com

www.pudica.ir

CREADITS: This presentation was created by M.Razeghizadeh
Please keep this slide for attribution